

## Operation Instructions

- Open dispenser cover by pressing keyless lock. (H)
- Insert two "C" cell alkaline batteries. (I)
- Turn dispenser **ON** by pressing **ON/OFF** button. (E)
- Dispenser is factory set with **AUDIO ON** (dispenser will function with audio signals reinforcing the need to replace a refill and/or batteries). You may deactivate the **AUDIO** by pressing the **TONE** button (D) (dispenser will function without audio signals).
- The factory setting will be displayed on LCD display. (G)

If factory settings are satisfactory proceed to step 6. If you wish to change the settings, follow Steps 1 - 5 below.

### Step 1. Select Dispensing Level

- Press the **MODE** button (A) to select the level of dispensing.
- Press the **ADJUST** button (B) to move between options: **ME** (Medium), **HI** (High), **Lo** (Low)
- Press **ENTER** (C) to save selected setting.
- Display will show number of days in refill cycle. (G)

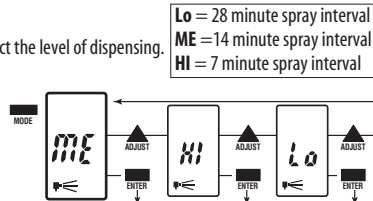

### Step 2. Set Time Clock

- Press **MODE** to set the time.
- Press **ADJUST** to adjust clock by increments of 10 min.
- Press **ENTER** once real time is shown.

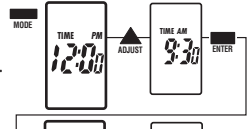

### Step 3. Select number of hours of operation

- Press **ADJUST** to choose 12 or 24 hour operation.
- Press **ENTER** to save selected setting.
- If you choose a 12 hour setting:
  - Press **ADJUST** to set the start time of 12 hour period.
  - Press **ENTER** once desired start time is shown.
  - Display will show number of days in refill cycle.

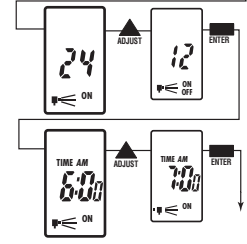

### Step 4. Set the day of the week

- Press **MODE** to set the day of the week.
- Press **ADJUST** to scroll through days.
- Press **ENTER** once actual day is shown.

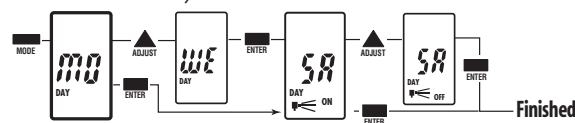

### Step 5. Select days of operation

- Press **ADJUST** to select if dispenser should be **ON** or **OFF** for the day shown on the display.
  - Press **ENTER** to save setting.
- NOTE: Dispenser operates a 5, 6 or 7 day cycle.

### Step 6. Refilling Dispenser

- Press the red **RESET** (J) button for up to 4 seconds. **IMPORTANT: Do this every time a refill is replaced.** If reset button is pressed for 5 seconds, the dispenser will automatically switch to "Demo" mode and revert to factory setting of 30 days.
- Insert refill and close cover. **Do not stand directly in front of dispenser.**

### Step 7. Changing Batteries

- Dispenser will hold the display for 1 minute, allowing you to change the battery without losing the setting. Battery life approximately 3 years.
- Visual battery monitor will flash when battery reaches last 30 days of life.

## Setting Flow Chart

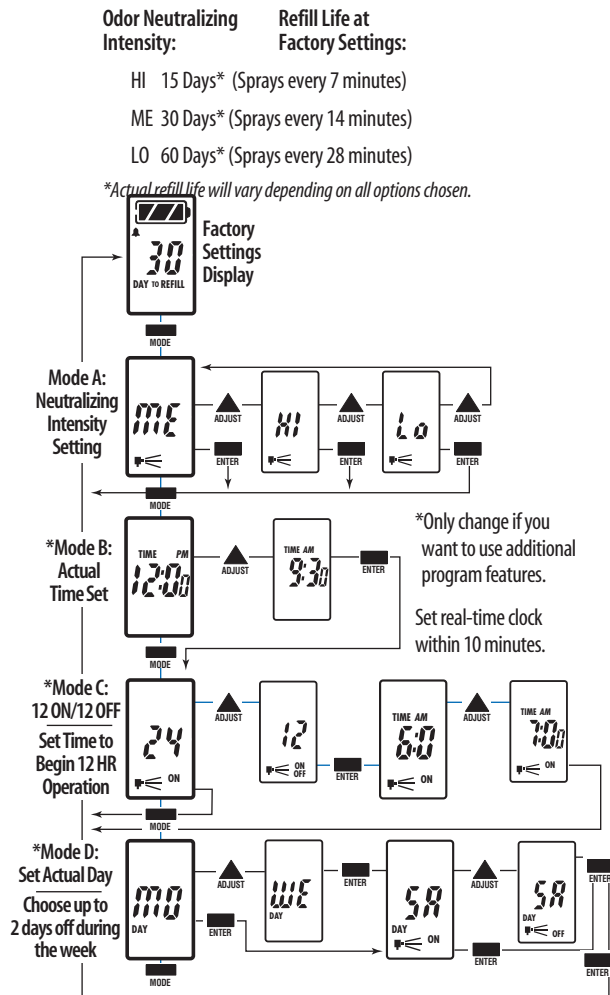

Remember this simple process:

- Press **MODE** to scroll thru options
- Press **ADJUST** to adjust choice in options
- Press **ENTER** to enter choice into program

Repeat steps 1, 2 & 3 for each option available.

## INSTALLATION INSTRUCTIONS

### Wall Mounting

- Dispenser should be positioned at a minimum height of 7' (2.2m) for best results.
- Position the Dispenser over a wall stud and secure with supplied screws.

### Montage sur le mur

- Le dispensateur doit être positionné à une hauteur de 7" (2.2 m) pour obtenir un meilleur résultat.
- Positionner le dispensateur sur l'appui du mur et visser avec les vis fournies.

### Montaje sobre la pared

- El dispensador debe estar ubicado a una altura mínima de 7" (2.2 m) para obtener un mejor resultado.
- Ubicar el dispensador sobre el montante de la pared y atornillar con los tornillos provistos.

### Wall Mounting (Japanese)

- Dispenser should be positioned at a minimum height of 7' (2.2m) for best results.
- Position the dispenser over a wall stud and secure with supplied screws.

### Wall Mounting (Chinese)

- Dispenser should be positioned at a minimum height of 7' (2.2m) for best results.
- Position the Select Dispenser over a wall stud and secure with supplied screws.

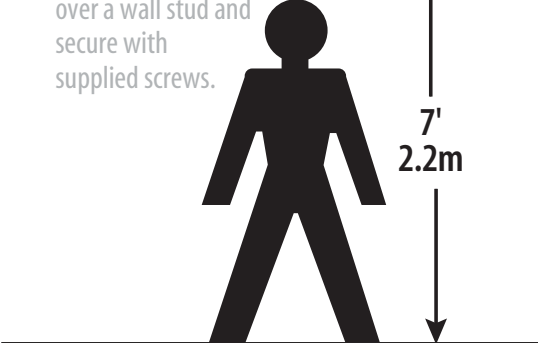

## Have Questions or Need Supplies?

Call Toll Free: 1-800-551-5155

or on the web:

[www.technicalconcepts.com](http://www.technicalconcepts.com)



Remember to register for your dispenser warranty on-line at: <http://www.technicalconcepts.com>  
Use of air neutralizers other than TC™ refills voids dispenser warranty.



### Technical Concepts L.P.

World Headquarters/USA:  
1301 Allanson Road  
Mundelein, Illinois 60060  
☎ 847-837-4100  
☎ 847-837-4110  
E-mail: [info@technicalconcepts.com](mailto:info@technicalconcepts.com)

### Technical Concepts International Ltd.

European Headquarters:  
Pin Green Business Park, Eastman Way  
Stevenage, Herts SG1 4UH, England  
☎ +44 (0) 870 568 6824  
☎ +44 (0) 1438 311200  
E-mail: [info\\_europe@technicalconcepts.com](mailto:info_europe@technicalconcepts.com)

### Technical Concepts Asia

Malaysia Headquarters:  
51 (B) Lorong Perindustrian  
Bukit Minyak 9  
14100 Bukit Mertajam  
Penang, Malaysia  
☎ (60) 4 508 5008  
☎ (60) 4 508 5001  
E-mail: [info\\_asia@technicalconcepts.com](mailto:info_asia@technicalconcepts.com)

**MICROBURST**  
LCD  
**3000** AEROSOL  
DISPENSER

Distributeur LCD en aérosol Microburst 3000  
Dispensador LCD en aerosol Microburst 3000

Japanese  
Chinese

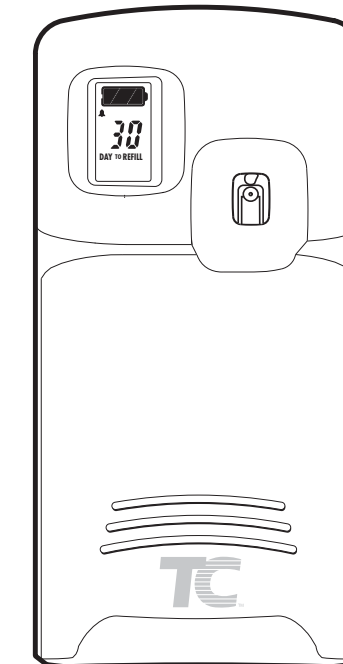

Smells Clean - Is Clean.™



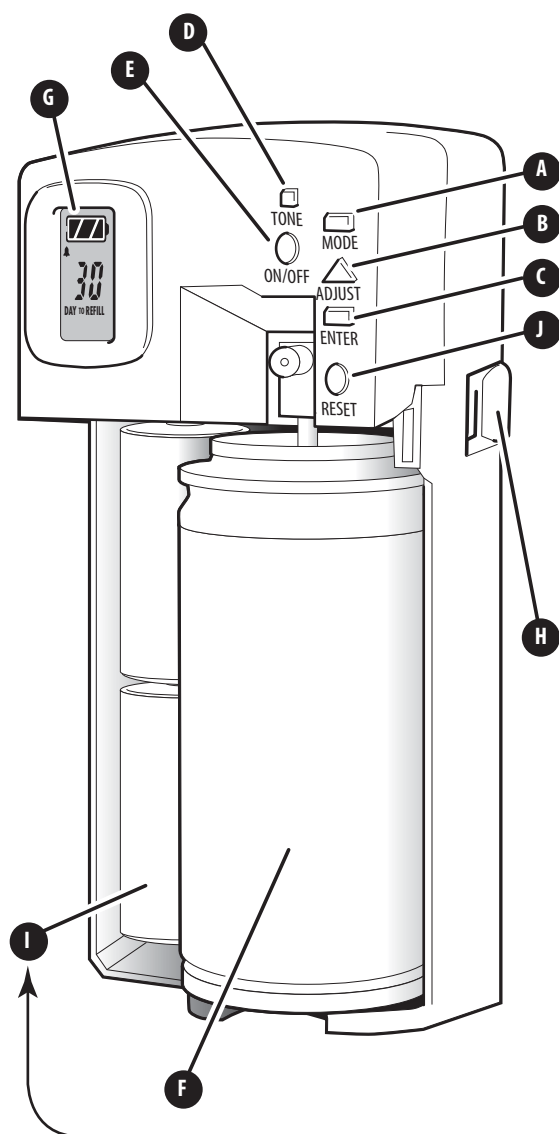

**MUST USE ALKALINE BATTERIES**  
**UTILISER SEULEMENT DES PILES ALCALINES**  
**USAR SOLAMENTE PILAS ALCALINAS**

### Mode d'emploi

- Ouvrir le couvercle du distributeur en appuyant sur la fermeture sans clé (H).
  - Installer deux piles alcalines de format "C". (I).
  - Tourner le distributeur sur ON en appuyant sur le bouton ON/OFF. (E)
  - Le distributeur est réglé à la manufacture avec la fonction AUDIO ON (le distributeur fonctionnera avec les signaux sonores pour renforcer le besoin de remplacer la recharge de gel ou/et les piles). Vous pouvez désactiver la fonction AUDIO en appuyant sur le bouton TONE (E) (le distributeur fonctionnera sans les signaux sonores).
  - Les réglages seront affichés sur l'affichage LED (G).
- Si les réglages en usine vous conviennent, passer à l'étape 6. Sinon, suivre les étapes 1 à 5 ci-dessous.

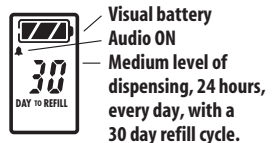

#### Étape 1. Choisir le niveau de distribution

- Appuyer sur le bouton MODE (A) pour sélectionner le niveau de distribution.
- Appuyer sur le bouton ADJUST (B) pour se déplacer d'une option à l'autre ME (Moyen), HI (Élevé), Lo (Bas).
- Appuyer sur ENTER (C) pour sauvegarder les réglages sélectionnés.
- L'affichage indiquera le nombre de jours dans le cycle de recharge. (G).

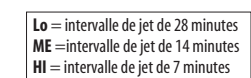

#### Étape 2. Régler l'horloge

- Appuyer sur MODE pour régler l'heure.
- Appuyer sur ADJUST pour régler l'horloge en augmentant de 10 minutes à la fois.
- Appuyer sur ENTER lorsque l'heure réelle est affichée.

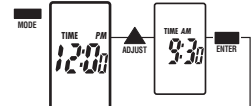

#### Étape 3. Sélectionner le nombre d'heures de fonctionnement

- Appuyer sur ADJUST pour régler un fonctionnement de 12 ou 24 heures.
- Appuyer sur ENTER pour sauvegarder le réglage sélectionné.
- Si vous choisissez un réglage de 12 heures:
- Appuyer sur ADJUST pour régler l'heure de départ de la période de 12 heures.
- Appuyer sur ENTER lorsque l'heure de départ de la période de 12 heures est affichée.
- L'affichage indiquera le nombre de jours dans le cycle de recharge.

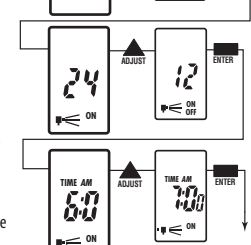

#### Étape 4. Régler le jour de la semaine

- Appuyer sur MODE pour régler le jour de la semaine.
- Appuyer sur ADJUST pour dérouler les jours.
- Appuyer sur ENTER lorsque le jour réel est affiché.

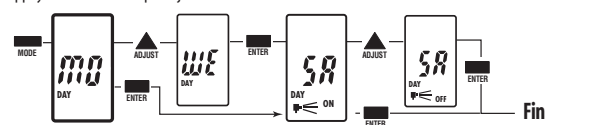

#### Étape 5. Sélectionner les jours de fonctionnement

- Appuyer sur ADJUST pour choisir si le distributeur devrait être en position de fonctionnement ON ou d'arrêt OFF pour le jour affiché sur l'affichage.
- Appuyer sur ENTER pour sauvegarder le réglage.
- REMARQUE : Le distributeur fonctionne sur un cycle de 5, 6 ou 7 jours.

#### Étape 6. Recharge du distributeur

- Appuyer sur le bouton rouge RESET (J) pendant une durée de 4 secondes. **IMPORTANT: Faire cela chaque fois qu'une recharge est remplacée.** Si vous appuyez sur le bouton de remise à zéro pendant 5 secondes, le distributeur passera automatiquement au mode "Demo" et retournera au réglage en usine de 30 jours.
- Placer la recharge et fermer le couvercle. **Ne pas se tenir directement en face du distributeur.**

#### Étape 7. Remplacement des piles

- Le distributeur maintiendra l'affichage pendant 1 minute pour vous donner le temps de changer les piles sans perdre les réglages. Le durée d'utilisation des piles est d'environ 3 ans.
- Le voyant lumineux des piles clignotera lorsque les piles ont atteint les derniers 30 jours de leur durée d'utilisation.

### Modo de empleo

- Abrir la tapa del dispensador apretando la cerradura sin llave. (H)
  - Insertar dos pilas alcalinas "C". (I)
  - Encender el dispensador apretando el botón ON/OFF. (E)
  - El dispensador viene de fábrica con el AUDIO ON (el dispensador va a funcionar con la señal de audio reforzando la necesidad de reemplazar el repuesto de gel o las pilas). Usted puede desactivar el AUDIO apretando el botón TONE (E) (el dispensador funcionará sin la señal de audio).
  - El ajuste de fábrica aparecerá en el indicador LCD. (G)
- Si los ajustes de fábrica son satisfactorios proceder a la etapa 6. Si usted desea cambiar los ajustes, siga las etapas 1 a 5 a continuación.

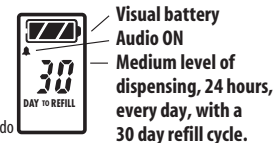

#### Eta 1. Seleccionar el nivel de dispensación

- Apretar el botón MODE (A) para seleccionar el nivel de dispensación.
- Apretar el botón ADJUST (B) para moverse entre las opciones: ME (medio), HI (alto), Lo (bajo).
- Apretar ENTER (C) para salvaguardar el ajuste seleccionado.
- El indicador mostrará el número de días en el ciclo de recarga. (G)

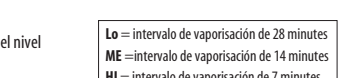

#### Eta 2. Ajustar el reloj

- Apretar MODE para ajustar la hora.
- Apretar ADJUST para ajustar el reloj en incrementos de 10 minutos.
- Apretar ENTER una vez que aparece la hora correcta.

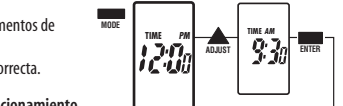

#### Eta 3. Seleccionar el número de horas de funcionamiento.

- Apretar ADJUST para elegir 12 o 24 horas de funcionamiento.
- Apretar ENTER para salvaguardar el ajuste seleccionado.
- Si usted selecciona 12 horas:
- Apretar ADJUST para fijar la hora de comienzo del periodo de 12 horas.
- Apretar ENTER una vez que la hora deseada de comienzo aparece en el indicador.
- El dispensador mostrará el número de días en el ciclo de recarga.

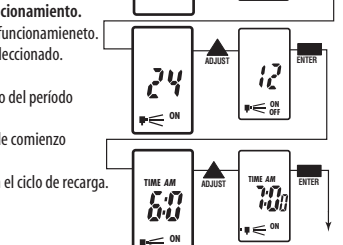

#### Eta 4. Fijar el día de la semana

- Apretar MODE para fijar el día de la semana.
- Apretar ADJUST para seleccionar el día de la semana.
- Apretar ENTER una vez que aparece el día correcto.

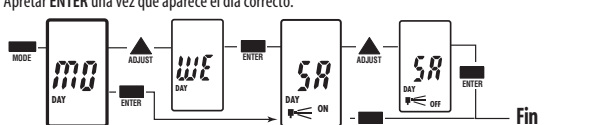

#### Eta 5. Seleccionar los días de funcionamiento

- Apretar ADJUST para seleccionar si el dispensador debe estar en ON u OFF para el día que aparece en el indicador.
- Apretar ENTER para salvaguardar la selección.
- NOTA: El dispensador funciona en ciclos de 5, 6 o 7 días.

#### Eta 6. Recarga del dispensador

- Apretar el botón rojo RESET (J) durante 4 segundos. **IMPORTANT: Hacer esto cada vez que se cambie la recarga.** Si el botón RESET se aprieta por 5 segundos, el dispensador automáticamente cambiará a la modalidad de "Demo" y retornará al ajuste de fábrica de 30 días.
- Insertar la recarga y cerrar la tapa. **No pararse enfrente del dispensador.**

#### Eta 7. Cambio de pilas

- El dispensador mantendrá la indicación por 1 minuto, para permitirle el cambio de pilas sin perder los ajustes. La pila dura aproximadamente 3 años.
- La imagen de la pila empezará a guñar cuando a la pila le queden 30 días de vida.

### Japanese Operation Instructions

- Open dispenser cover by pressing keyless lock. (H)
  - Insert two "C" cell alkaline batteries. (I)
  - Turn dispenser ON by pressing ON/OFF button. (E)
  - Dispenser is factory set with AUDIO ON (dispenser will function with audio signals reinforcing the need to replace a refill and/or batteries). You may deactivate the AUDIO by pressing the TONE button (E) (dispenser will function without audio signals).
  - The factory setting will be displayed on LCD display. (G)
- If factory settings are satisfactory proceed to step 6. If you wish to change the settings, follow Steps 1 - 5 below.

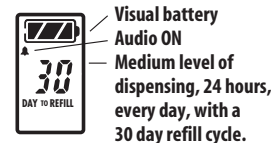

#### Step 1. Select Dispensing Level

- Press the MODE button (A) to select the level of dispensing.
- Press the ADJUST button (B) to move between options: ME (Medium), HI (High), Lo (Low)
- Press Enter (C) to save selected setting.
- Display will show number of days in refill cycle. (G)

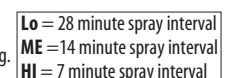

#### Step 2. Set Time Clock

- Press MODE to set the time.
- Press ADJUST to adjust clock by increments of 10 minutes.
- Press ENTER once real time is shown.

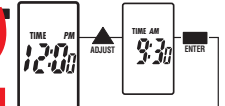

#### Step 3. Select number of hours of operation

- Press ADJUST to choose 12 or 24 hour operation.
- Press ENTER to save selected setting.
- If you choose a 12 hour setting:
- Press ADJUST to set the start time of 12 hour period.
- Press ENTER once desired start time is shown.
- Display will show number of days in refill cycle.

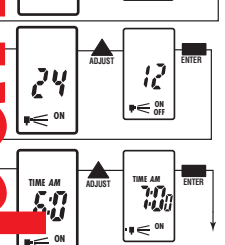

#### Step 4. Set the day of the week

- Press MODE to set the day of the week.
- Press ADJUST to scroll through days.
- Press ENTER once actual day is shown.



#### Step 5. Select days of operation

- Press ADJUST to select if dispenser should be ON or OFF for the day shown on the display.
- Press ENTER to save setting.
- NOTE: Dispenser operates a 5, 6 or 7 day cycle.

#### Step 6. Refilling Dispenser

- Press the red RESET (J) button for up to 4 seconds. **IMPORTANT: Do this every time a refill is replaced.** If reset button is pressed for 5 seconds, the dispenser will automatically switch to "Demo" mode and revert to factory setting of 30 days.
- Insert refill and close cover. **Do not stand directly in front of dispenser.**

#### Step 7. Changing Batteries

- Dispenser will hold the display for 1 minute, allowing you to change the battery without losing the setting. Battery life approximately 3 years.
- Visual battery monitor will flash when battery reaches last 30 days of life.

### Chinese Operation Instructions

- Open dispenser cover by pressing keyless lock. (H)
  - Insert two "C" cell alkaline batteries. (I)
  - Turn dispenser ON by pressing ON/OFF button. (E)
  - Dispenser is factory set with AUDIO ON (dispenser will function with audio signals reinforcing the need to replace a refill and/or batteries). You may deactivate the AUDIO by pressing the TONE button (E) (dispenser will function without audio signals).
  - The factory setting will be displayed on LCD display. (G)
- If factory settings are satisfactory proceed to step 6. If you wish to change the settings, follow Steps 1 - 5 below.

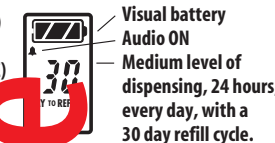

#### Step 1. Select Dispensing Level

- Press the MODE button (A) to select the level of dispensing.
- Press the ADJUST button (B) to move between options: ME (Medium), HI (High), Lo (Low)
- Press Enter (C) to save selected setting.
- Display will show number of days in refill cycle. (G)

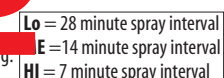

#### Step 2. Set Time Clock

- Press MODE to set the time.
- Press ADJUST to adjust clock by increments of 10 minutes.
- Press ENTER once real time is shown.

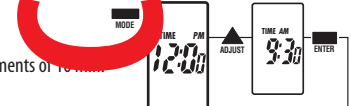

#### Step 3. Select number of hours of operation

- Press ADJUST to choose 12 or 24 hour operation.
- Press ENTER to save selected setting.
- If you choose a 12 hour setting:
- Press ADJUST to set the start time of 12 hour period.
- Press ENTER once desired start time is shown.
- Display will show number of days in refill cycle.

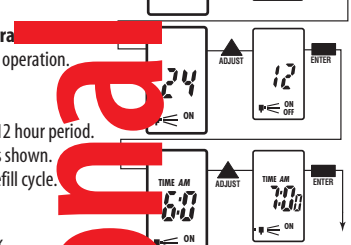

#### Step 4. Set the day of the week

- Press MODE to set the day of the week.
- Press ADJUST to scroll through days.
- Press ENTER once actual day is shown.



#### Step 5. Select days of operation

- Press ADJUST to select if dispenser should be ON or OFF for the day shown on the display.
- Press ENTER to save setting.
- NOTE: Dispenser operates a 5, 6 or 7 day cycle.

#### Step 6. Refilling Dispenser

- Press the red RESET (J) button for up to 4 seconds. **IMPORTANT: Do this every time a refill is replaced.** If reset button is pressed for 5 seconds, the dispenser will automatically switch to "Demo" mode and revert to factory setting of 30 days.
- Insert refill and close cover. **Do not stand directly in front of dispenser.**

#### Step 7. Changing Batteries

- Dispenser will hold the display for 1 minute, allowing you to change the battery without losing the setting. Battery life approximately 3 years.
- Visual battery monitor will flash when battery reaches last 30 days of life.

Translated Chinese