

# SelectLine®

## Floor Machines

The Kent SelectLine® models are multi-purpose floor machines and are solid performers among everyday users. All models are made of steel with chrome-plated bell housing and a handle shaft with compression-style hand-height adjustment. All models are versatile and are made to clean, strip or polish almost any floor surface. Some other applications include carpet bonneting or shampooing and gym floor screening. Choose either a 13-inch (33 cm), 17-inch (43.2 cm), or 20-inch (50.8 cm) to fit any application.

The SelectLine models come standard with comfortable and solid handles with safety interlock activation to prevent accidental start-up. A convenient compression-style foot pedal lock allows handle adjustment to any operator's height. The heavy gauge, chrome-plated steel handle provides maximum machine control, strength and durability. Powerful motor and dual or triple (SelectLine 17HD, 20HD and 20TS) planetary gear systems provide smooth, quiet and reliable operation. High torque system allows for smooth start-ups on all hard floor surfaces. The quick-release pad/brush system makes pad holder and brush changes fast and easy – while non-marking transport wheels are long-wearing and protect floors from damage. The SelectLine 17HD, 20HD and 20TS provide more torque, better cooling and easy maneuverability. The SelectLine® 20TS (two-speed) floor machine offers 180/320 rpm, giving extra revolutions when needed.

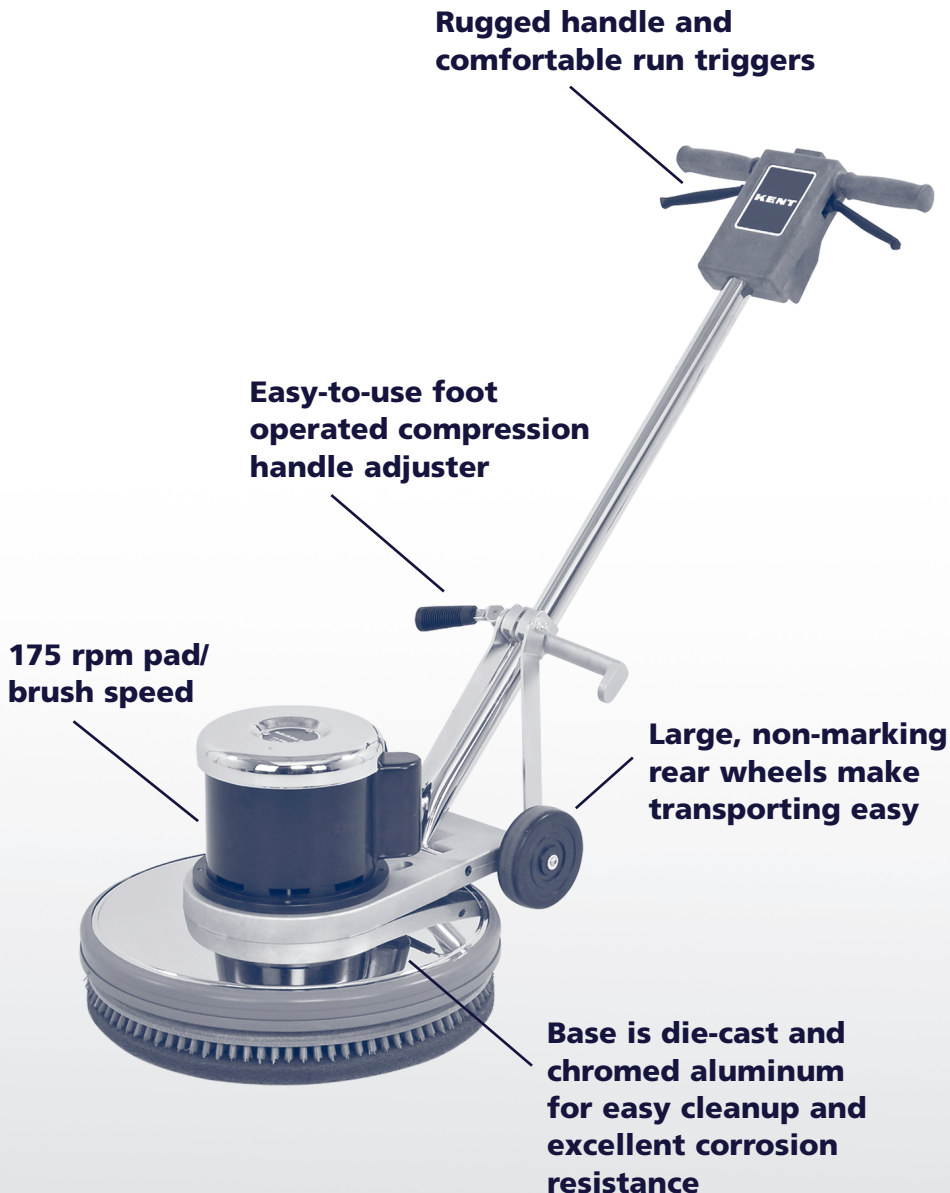

### The SelectLine® models are perfect for...

- Schools and Universities
- Supermarkets
- Hospitals
- Office Buildings
- Hotels and Motels

**KENT**  
Simple. Clean.

# TECHNICAL SPECIFICATIONS

Models	SelectLine 13	SelectLine 17	SelectLine 20	SelectLine 17HD	SelectLine 20HD	SelectLine 20TS
Pad / Brush Size	13 in (33 cm)	17 in (43.2 cm)	20 in (50.8 cm)	17 in (43.2 cm)	20 in (50.8 cm)	20 in (50.8 cm)
Pad Drive System						
Motor Horsepower	1.0 hp AC	1.0 hp AC	1.0 hp AC	1.5 hp AC	1.5 hp AC Rectified	1.5 hp DC
Frame Size	66	66	66	66	66	66
Motor Amps	12.6 A	12.6 A	12.6 A	15 A	15 A	15 A
Capacitors	Dual, start and run	Dual, start and run	Dual, start and run	Dual, start and run	Dual, start and run	
Motor Voltage	120 V	120 V	120 V	120 V	120 V	120 V
Revolutions Per Minute	175 rpm	175 rpm	175 rpm	175 rpm	175 rpm	180/320 rpm
Transmission	Dual planetary gears – all metal	Dual planetary gears – all metal	Dual planetary gears – all metal	Triple planetary gears – all metal	Triple planetary gears – all metal	Triple planetary gears – all metal
Clutch Plate	NP 92 (industry standard)	NP 92 (industry standard)	NP 92 (industry standard)	NP 92 (industry standard)	NP 92 (industry standard)	NP 92 (industry standard)
Body Construction	All steel with chrome-plated bell housing and handle shaft with compression-style handle-height adjustment. Includes rubber wheels for transportation. – All Models					
Machine Weight	81 lb (37 kg)	90 lb (41 kg)	93 lb (42 kg)	100 lb (45 kg)	102 lb (46 kg)	87 lb (40 kg)
Power Cord						
Power Cord Length	50 ft/ 15.25 m – All Models					
Power Cord Type	Safety Yellow Super-flex with hospital grade plug – All Models					
Operator Handle	Comfortable and solid handle with safety interlock activation preventing accidental start-up – All Models					
Noise Level	65 dB A	65 dB A	65 dB A	65 dB A	65 dB A	70 dB A
Approvals	ETL, CSA	ETL, CSA	ETL, CSA	ETL, CSA	ETL, CSA	ETL, CSA
Part Numbers	01283A	01300A	01380A	01340A	01420A	01450A

Specifications are subject to change without notice.



*Dual capacitors standard for extra power at start-up and during operation*



*Quick release pad/brush system makes pad holder and brush changes fast and easy*



*Chrome bell housing looks great, resists corrosion and is easier to clean*

## Optional Accessories Include...

- A variety of brushes
- Level-set pad holder
- Splash Guard
- Handle-mount solution tank



# KENT

Simple. Clean.

14600 21st Avenue North  
Plymouth, Minnesota 55447-3408  
www.kenturoclean.com  
Phone 800-545-4372  
Fax 866-261-4779

240 Superior Boulevard  
Mississauga, Ontario, Canada L5T 2L2  
www.kenturoclean.com  
Phone 905-564-1149 or 800-668-8400  
Fax 905-564-1030 or 800-263-5111