

# 50 Gallon / 189 Liter Stainless Steel **ROUND DUAL SIDE-ENTRY** **INDOOR TRASH CAN with Removable Ashtray**

Offer quick and effective waste disposal in entryways, lobbies, stores and more, with the **HLS Commercial® Round Dual Side-Entry Indoor Trash Can with Removable Ashtray**. The elegant, durable stainless steel complements any décor, while the versatile round shape allows it to fit into any space and the two large side openings offer quick and convenient disposal.



## FEATURES

- ✓ **DUAL SIDE-ENTRY OPENINGS FACILITATE EASY DISPOSAL IN BUSY SETTINGS**
- ✓ **EXTRA-LARGE 50 GALLON CAPACITY**
- ✓ **REMOVABLE ASHTRAY HOLE COVER INCLUDED**
- ✓ **VERSATILE ROUND SHAPE FITS ANY LOCATION**
- ✓ **STAINLESS STEEL IS SMUDGE-RESISTANT**

**HLS50DSI**



UnoClean.com  
(224) 654-6500

# SPECIFICATIONS

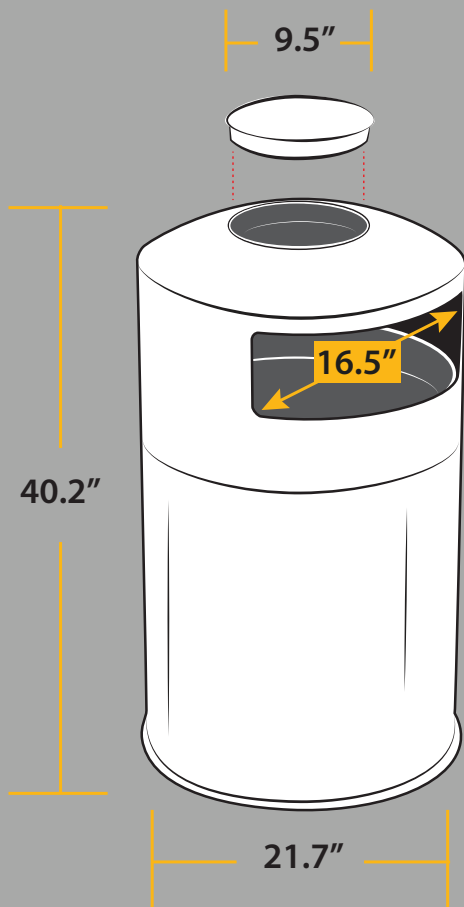

**Model:** HLS50DSI

**Use:** Indoor

**Dimensions:** 21.7" L x 21.7" W x 40.2" H

**Package Dimensions:** 24.8" L x 24.8" W x 43.3" H

**Product Weight:** 29.1 lbs.

**Package Weight:** 39.02 lbs.

**Capacity:** 50 Gallons (189 Liters)

**Material:** Stainless Steel