



MADE IN THE USA

Alternate Products (each sold separately):

- MB-510: Hanger - Wall (shown below)



Product Description:

- Hanger - Glass and Laminate
- Holds BOWMAN® Protection Systems
- Attaches with semi-permanent VHB (Very High Bond) double-sided tape
- Keyholes for wall mounting only
- Quartz Beige Powder-Coated Steel

Primary Area for Product Usage:

- Anywhere protective equipment products are needed

Package Specifications:

- Package Quantity: 12 per case
- 12"W x 6"H x 6"D (30.5 cm x 15.2 cm x 15.2 cm)
- 8.0 lbs (3.6 kg) - approximated

Product Specifications (overall external dimensions):

- 10.00"W x 4.62"H x 0.56"D (25.4 cm x 11.7 cm x 1.4 cm)
- 0.5 lb (0.2 kg) - approximated

Mounting Specifications:

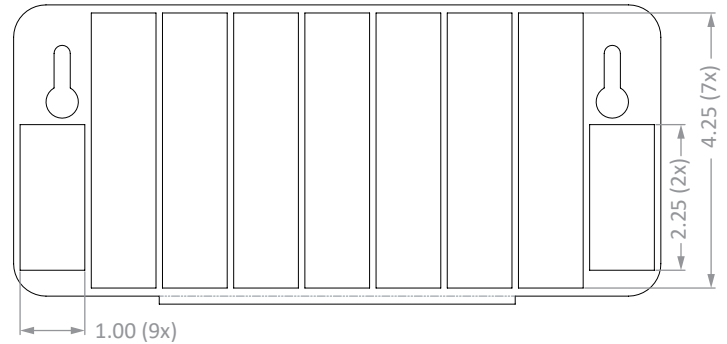

Proper Hanging Procedure:

- 1) Clean mounting surface using a mixture of 50:50 isopropyl alcohol and water prior to mounting the hanger.
- 2) Allow surface to dry completely. Remove the backing from all tape strips and press firmly to adhere tape to surface.
- 3) Allow adhesive a *minimum of 24 hours to set prior to mounting BOWMAN® Dispenser to the hanger. (*Tape is fully cured after 72 hours.)
- 4) Hang empty BOWMAN® Protection System on hanger.
- 5) Load consumables.
- 6) The hanger is rated to hold a maximum of 25 lbs. when mounted to glass or laminated wood. Not recommended for use on other surfaces.
- 7) Removal of product is not advised as damage to surface could occur.





Installation

Always mount dispensers securely *prior* to loading with product.

- See detailed instructions on page 1.

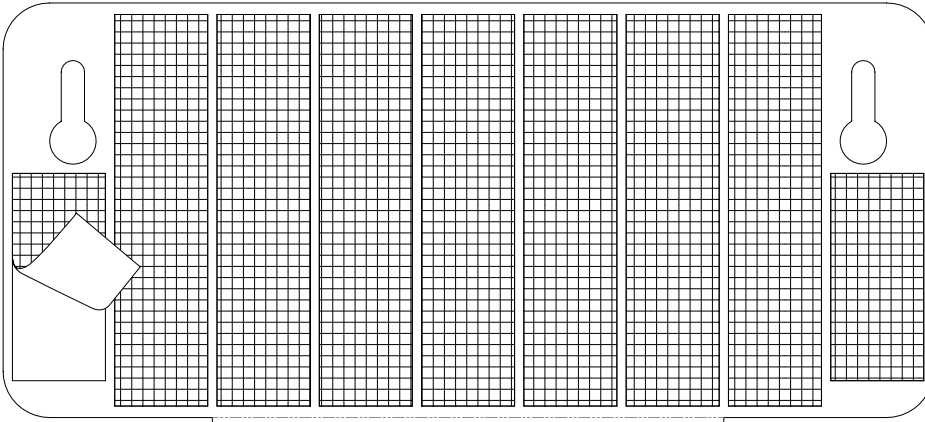
**1**

- Allow to cure minimum of 24 hours prior to hanging empty BOWMAN® Protection System.

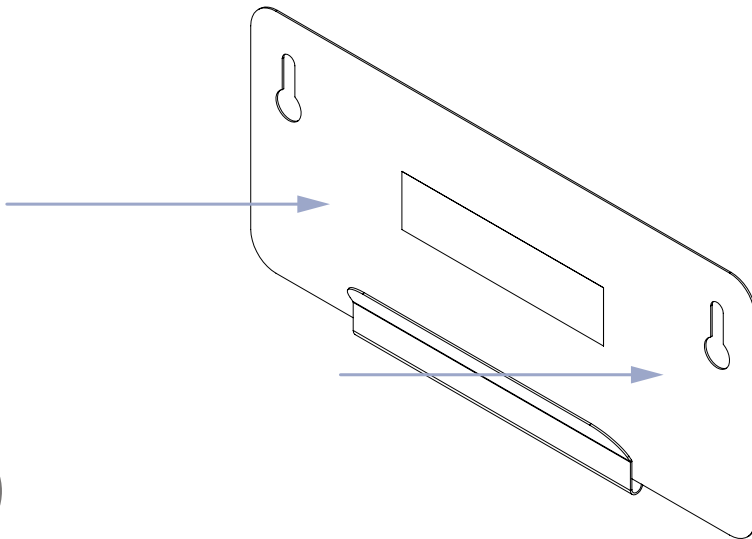
**2****Parts included:**

- Hanger

Tools Required:

- No tools required

Care and Construction

Powder-Coated Steel

Material Characteristics

Designed for Long-Term, Heavy-Duty Applications

Dispensers and stands made of powder-coated steel are both attractive and functional, providing years of service. Our powder-coated steel dispensers and stands provide long-lasting products that hold up well in tough environments.

Powder-coated steel is ideal for dispensers used in a healthcare or an industrial setting. It is impact resistant and is not effected by extremes in temperature.

Care and Cleaning

The powder-coated finish resists common chemicals and cleaning agents and can be easily wiped clean with soap and water.