



MADE IN THE USA

PATENT PENDING

Mounting Specifications:

- Installation should be performed only by a licensed contractor.

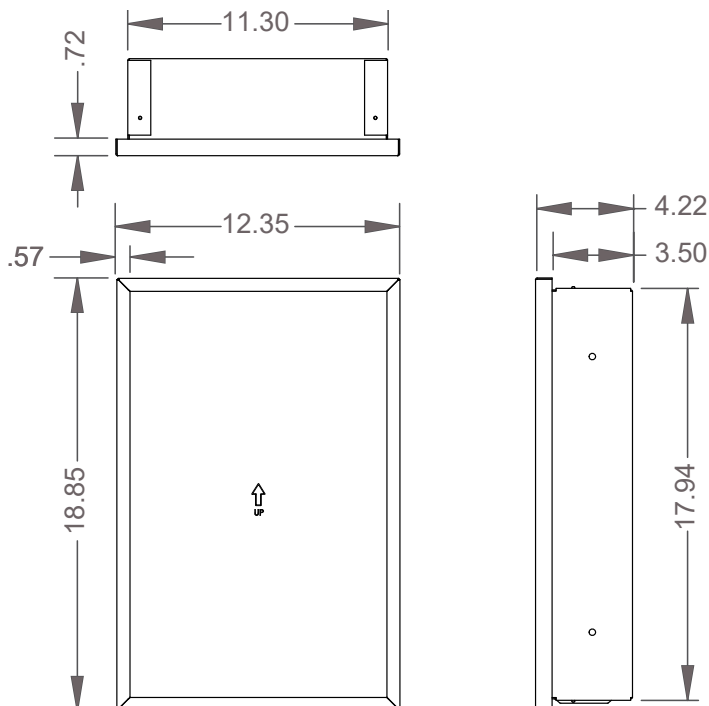

Product Description:

- Semi-Recessed Hand Sanitizer Dispenser
- Holds one hand sanitizer dispenser without installed drip tray
- Low profile
- Screw holes in sides to mount to stud framing in wall
- Made of Quartz Beige Powder-Coated Steel

Primary Area for Product Usage:

- All primary care areas: clinic/exam rooms, radiology, labs, physical therapy, O.R. areas, environmental services
- Ports of entry: waiting rooms, lobbies, elevators
- Medical offices or clinics

Dispenses:

- Most manufacturers' standard front-loading hand sanitizer dispensers
- Hand sanitizer dispensers (including required dispensing clearance) less than 11.30"W x 17.94"H x 5.00"D (28.7 cm x 45.6 cm x 12.7 cm)
- Refer to your hand sanitizer dispenser for space needed above to open and refill

Package Specifications:

- 24"L x 16"W x 6"H (61.0 cm x 40.6 cm x 15.2 cm)
- 9.0 lbs (4.1 kg) - approximated

Product Specifications (overall external dimensions):

- 12.35"W x 18.85"H x 4.22"D (31.4 cm x 47.9 cm x 10.7 cm)
- 7.4 lbs (3.4 kg) - approximated

In Use:





Installation

Always mount dispensers securely *prior* to loading with product.

- Install cabinet well *before* mounting hand sanitizer dispenser.
- Sanitizer backplate can be installed prior, if needed.
- The top of the cabinet is designated with an embossed UP stamp in the center.

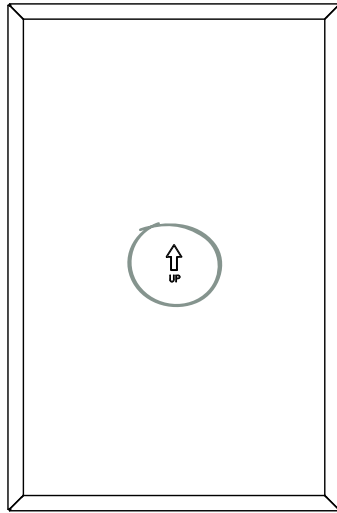

1

- Verify needed distance from top to allow for opening dispenser and refilling hand sanitizer.
- The amount of the hand sanitizer dispenser visible from the side will depend on the style and shape of dispenser chosen.

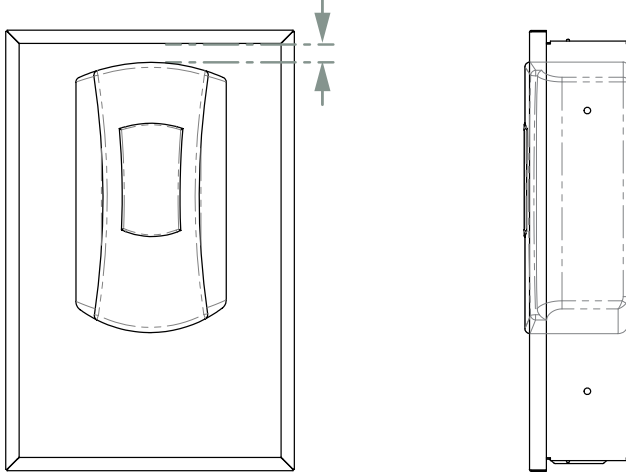

2

Parts included:

- Dispenser

Tools Required:

- No tools required to assemble dispenser

Characteristics & Care

Powder-Coated Steel

Material Characteristics

Designed for Long-Term Use

Our steel dispensers and stands are coated with polyester powders which makes them highly resistant to corrosion.

Powder-coated steel is ideal for dispensers used in a healthcare or an industrial setting because it is impact resistant and is not effected by extremes in temperature.

Dispensers and stands made of powder-coated steel are both attractive and functional, providing years of service.

Care and Cleaning

For best results, clean by washing the surface with a diluted solution of a mild, non-abrasive detergent in cold or warm water and a non-abrasive cloth. Standard hospital cleaning supplies can be used.

Dry with a soft cloth. Do not use any solvent-based materials, abrasives (e.g. Scotch-brite, steel wool), or apply excessive force during cleaning.