



MADE IN THE USA
PATENT PENDING

Accessories (each sold separately)

- MP-047: Sign Holder - Clip-On
- NC015-0111: Bulk Mask Adapter

Product Description:

- BOWMAN® PPE Cart II - Mobile Protection System
- Holds laundered or boxed gowns, earloop face masks or face shields, gloves, and has dedicated storage areas for additional isolation supplies
- Easy roll 3" casters with toe-locking brake
- Steel doors with magnetic closure
- Process indicators visually identify donning order
- Glove size indicators
- Clear PETG lid with 50 lb. maximum weight capacity
- Exceeds UL industry requirements for tipping stability
- California Phase 2 Compliant
- Safety Yellow Powder-Coated Aluminum and Steel, Gray Powder-Coated Aluminum, Brushed Nickel Hardware, and Clear PETG Lid
- Patent Pending

Primary Area for Product Usage:

- All patient care areas requiring personal protective equipment and isolation supplies

Dispenses/Stores:

- Gowns: about 75 flat pack gowns, 6-8 boxes of blue isolation gowns, about 136 unboxed blue isolation gowns, or 20-35 laundered*
- Face masks: 3 boxes of face shields or 6 boxes earloop face masks
- Gloves: 12 boxes of gloves
- Open shelf: 4-6 boxes of gowns, 4-5 packages of flat-pack gowns, 6-12 boxes of gloves, about 6 boxes of N-95 masks, or miscellaneous medical supplies*
- Enclosed shelves: up to 14 boxes of gowns, 10-12 packages of flat pack gowns, 42-56 boxes of gloves, or space for bouffant caps, shoe covers, extra boxes of face masks, or miscellaneous medical supplies*

* approximate - actual quantities dependent upon supply type and packaging

Product Specifications (overall external dimensions):

- 26.10"W x 53.38"H x 16.67"D (68.2 cm x 135.6 cm x 42.3 cm)
- 75.0 lbs (34.0 kg) - approximated

Package Specifications:

- Package Quantity: 1 per pallet
 - 48"L x 40"W x 64"H (121.9 cm x 101.6 cm x 162.6 cm)
 - 140.0 lbs (63.5 kg) - approximated +/- 10 lbs
- Package Quantity: 2 per pallet
 - 48"L x 40"W x 64"H (121.9 cm x 101.6 cm x 162.6 cm)
 - 230.0 lbs (104.3 kg) - approximated +/- 10 lbs



1

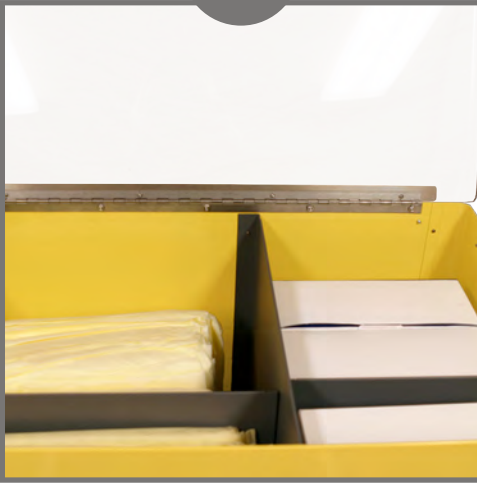

Top section holds gowns and face masks or shields for dispensing. Additional storage space is available in a divided compartment behind dispensing area.

2



Indicators show locations of glove sizes and proper donning procedure for personal protective equipment.

3



Glove area holds one box for dispensing and has storage available for three to four additional boxes in each size.

4



Magnetic closure doors conceal additional storage area for larger items such as shoe covers, bouffant caps, or any other isolation supplies.

5

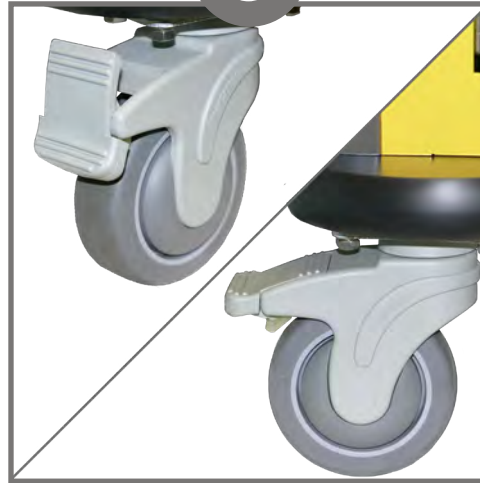

Cart features easy toe lock and unlock casters to immobilize cart for use.

6

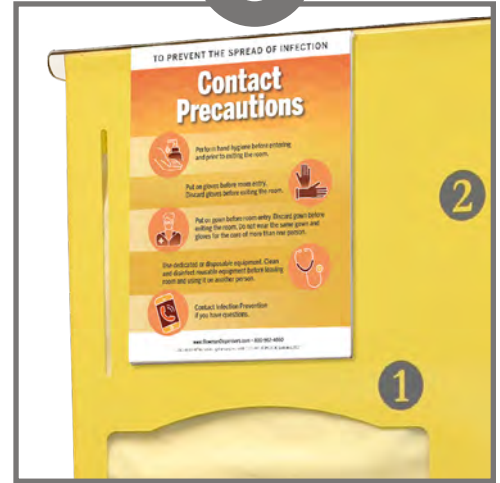

Clip on sign holder (MP-047, sold separately) available for signage.



1

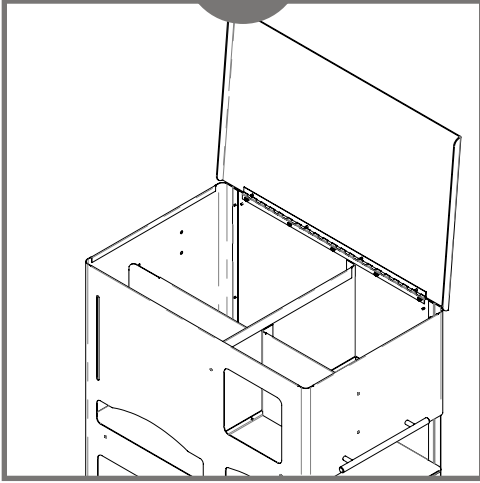

The cart is shipped with the gown divider in the upright position for use with flat pack or boxed gowns.

2

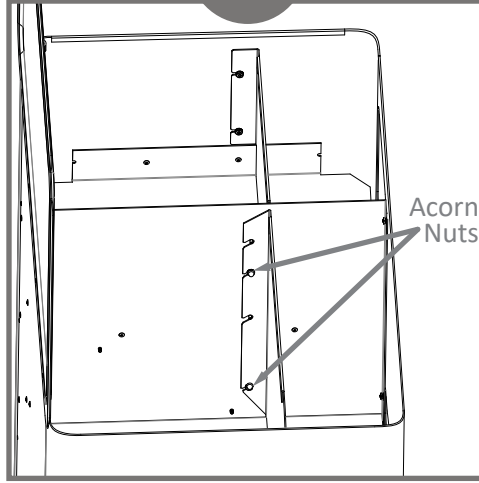

To dispense laundered gowns, loosen the four (4x) acorn nuts holding the divider in position.

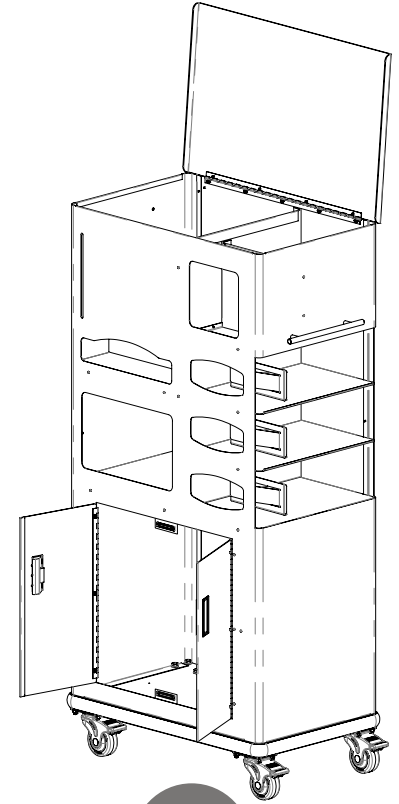

3

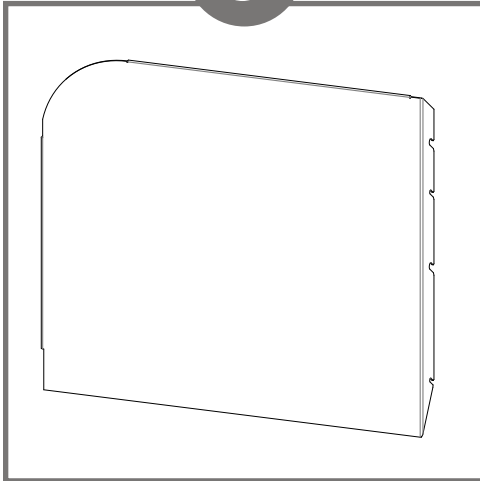

The sides of the divider have additional grooves for position adjustments.

4

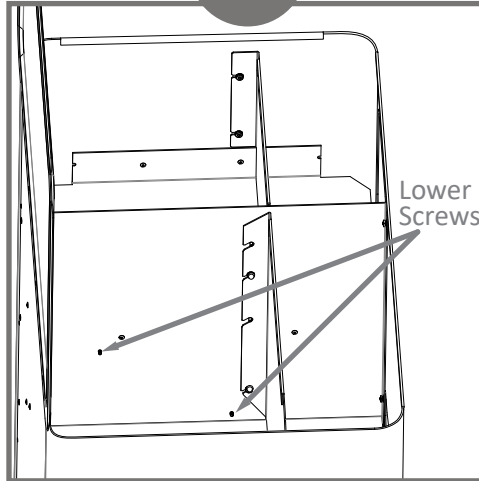

Keeping the rounded corner at the top left, reposition divider at a slanted position, resting on lower screws.

5

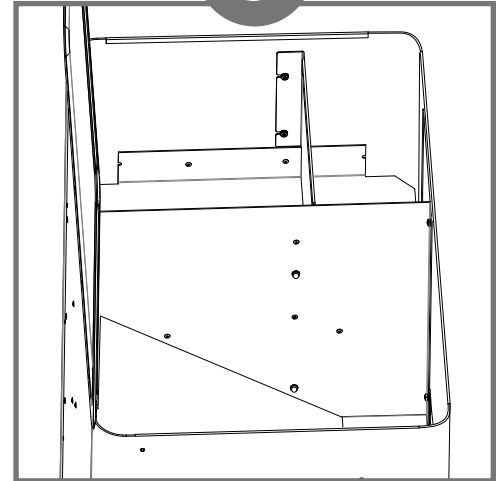

Retighten acorn nuts in original locations to protect dispensing of laundered gowns.

Parts included:

- Gown divider
- Four (4x) acorn nuts

Tools required:

- 5/16 nut driver

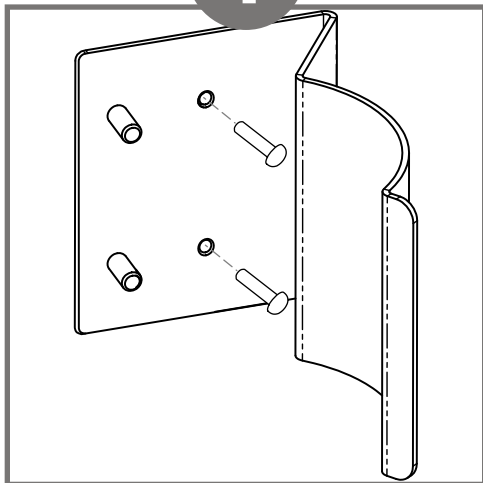
**1**

Attach right side of bracket to cart first, using included screws.

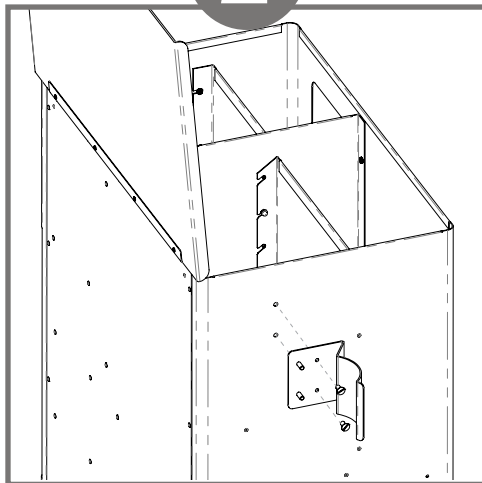
2

Attach bracket to cart through pre-threaded holes on left side of cart as shown.

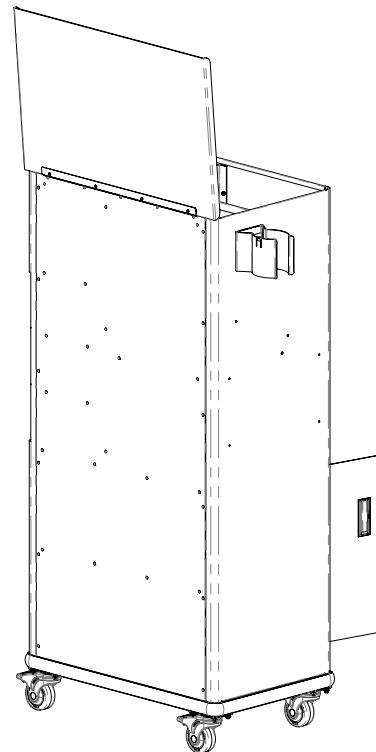
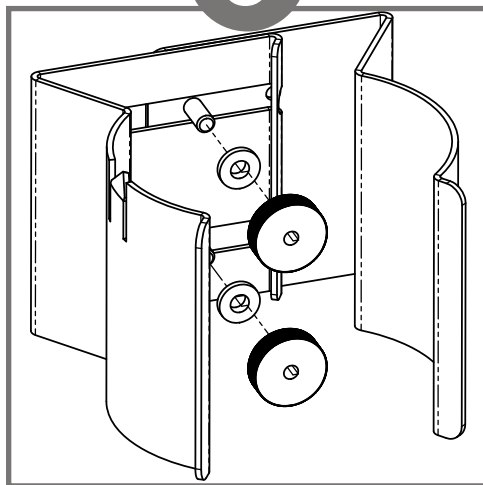
**3**

Place left side of bracket over mounting bolts and attach plastic washers and ridged knobs.

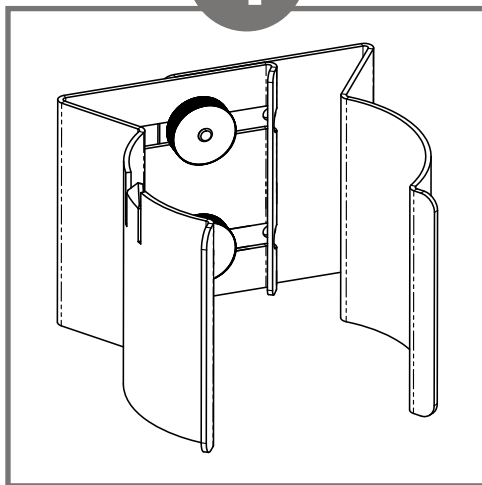
4

Determine size needed for disposable wipe canister and tighten plastic knobs at position needed to accommodate canister.

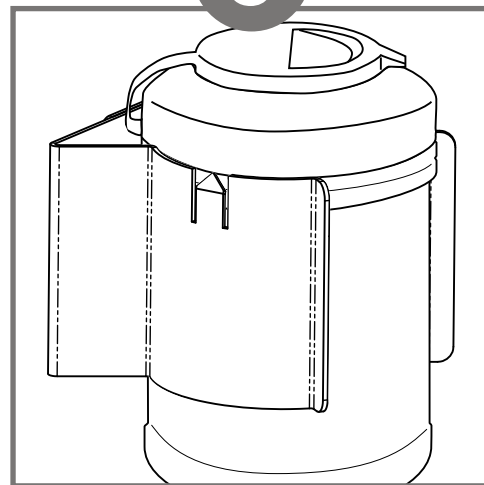
5

Slide wipe canister into dispenser from top down until pointed notch locks into rib or lip near the lid of the canister.

Parts included:

- Dispenser (2 parts)
- Two (2x) plastic washers
- Two (2x) plastic ridged knobs
- Two (2x) 10-32 combination head screws

Tools required:

- Phillips or flathead screwdriver to mount dispenser to cart

**Chassis**

Powder-Coated Aluminum

Doors

Powder-Coated Steel

Lid

PETG Plastic

Material Characteristics**Designed for Long-Term Use**

Our powder-coated aluminum dispensers resist corrosion, chipping, and flaking. It is lightweight, yet high in strength. This material will provide long-lasting products that hold up well, even in tough environments.

Powder-coated aluminum is ideal for dispensers used in a healthcare or industrial settings. It is impact resistant and is not affected by extremes in temperature.

Powder-coated aluminum is clean, bright, and attractive; it creates a professional appearance.

Designed for Long-Term Use

Our steel dispensers and stands are coated with polyester powders which makes them highly resistant to corrosion.

Powder-coated steel is ideal for dispensers used in a healthcare or an industrial setting because it is impact resistant and is not affected by extremes in temperature.

Dispensers and stands made of powder-coated steel are both attractive and functional, providing years of service.

Designed for Long-Term, Heavy Duty Applications

Copolyester resin is designed for heavy-duty applications, and is used by BOWMAN® Dispensers. We never use acrylic in our products.

Copolyester (PETG) is typically 15-20 times tougher than general purpose acrylic. PETG is made to withstand handling and reduce losses due to breakage.

PETG resists a variety of chemicals and commonly used cleaning agents, such as PDI wipes. It is tough and durable (not brittle), providing years of trouble-free functionality and long life.

Clear optical characteristics mean the viewer can see the content, read text, and see true colors through the material. It complies with FDA regulations for food contact.

Care and Cleaning

For best results, clean by washing the surface with a diluted solution of a mild, non-abrasive detergent in cold or warm water and a non-abrasive cloth. Standard hospital cleaning supplies can be used. Dry with a soft cloth. Do not use any solvent-based materials, abrasives (e.g. Scotch-brite, steel wool), or apply excessive force during cleaning.

For best results, clean by washing the surface with a diluted solution of a mild, non-abrasive detergent in cold or warm water and a non-abrasive cloth. Standard hospital cleaning supplies can be used. Dry with a soft cloth. Do not use any solvent-based materials, abrasives (e.g. Scotch-brite, steel wool), or apply excessive force during cleaning.

Most cleaning chemicals do not weaken the surface or cause damage to the material. Suggested cleaning method is to use a soft cloth, warm water, and mild soap.