



MADE IN THE USA

Product Description:

- Respiratory Supplies Dispenser
- Holds miscellaneous respiratory supplies
- Single compartment
- Holes for break away lock
- Hinged lid
- Keyholes for wall mounting
- Clear Polycarbonate Plastic

Primary Area for Product Usage:

- Anywhere respiratory supplies are needed

Dispenses:

- Holds bag valve mask, suction catheters, Yankauer suction tips, CPR masks, ET tubes, bite blocks, and more
- Item(s) no larger than 7.04"W x 15.70"H x 6.00"D (17.9 cm x 39.9 cm x 15.2 cm)

Package Specifications:

- Package Quantity: 1 per case
- 21"L x 13"W x 9"H (53.3 cm x 33.0 cm x 22.9 cm)
- 4.0 lbs (1.8 kg) - approximated

Product Specifications (overall external dimensions):

- 7.50"W x 18.27"H x 6.30"D (19.1 cm x 46.4 cm x 16.0 cm)
- 2.7 lbs (1.2 kg) - approximated

Mounting Specifications:

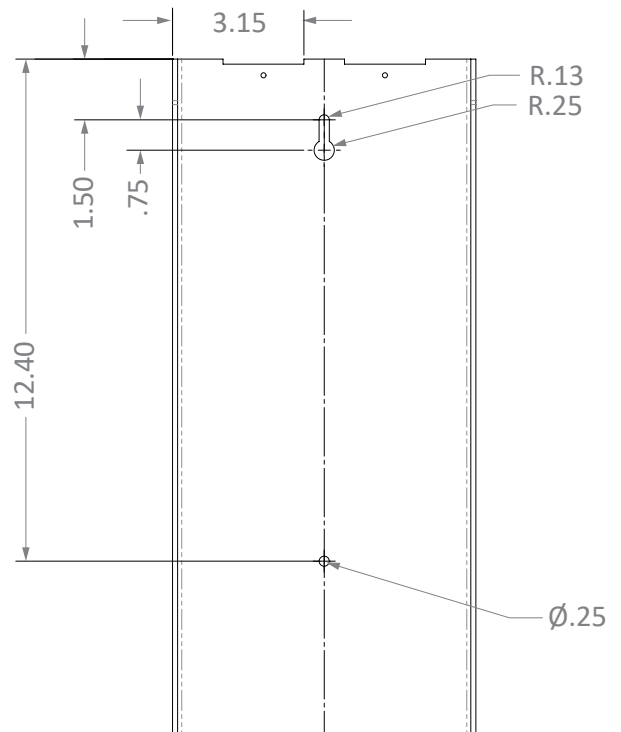

Alternative Products (each sold separately):

- RC001-0111: Bag Valve Mask Dispenser (special order) (shown below)





Installation

Always mount dispensers securely *prior* to loading with product.

- Mount securely to a wall with screws approved and supplied by building maintenance.

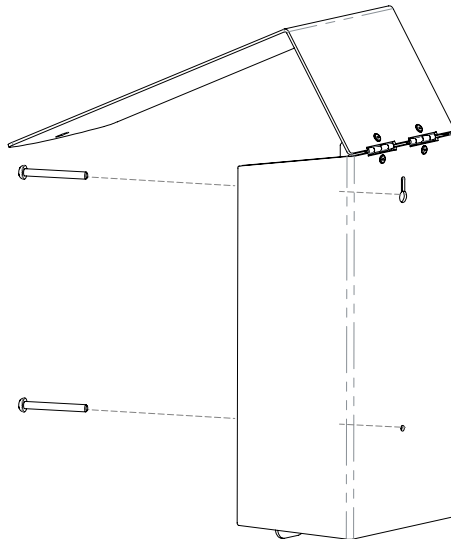

- Secure with zip tie or breakaway.

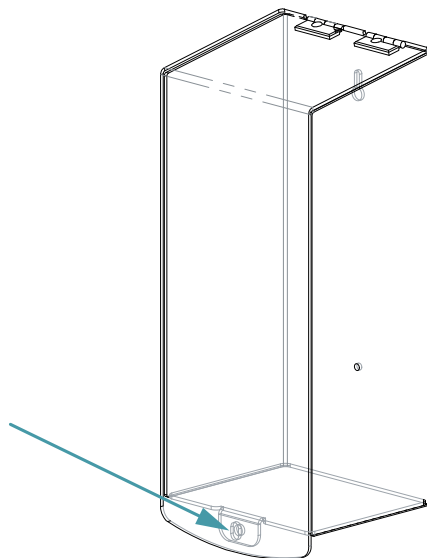

Parts included:

- Dispenser

Tools Required:

- No tools required to assemble dispenser

Care and Construction

Polycarbonate Plastic

Material Characteristics

Designed for Long-Term Heavy-Duty Applications

Polycarbonate plastic is a polymer comprised of Bisphenol A and phosgene, which makes it shatter resistant and provides an excellent combination of strength, rigidity, and toughness.

Our polycarbonate plastic is a clear, lightweight, tough, dimensionally stable thermoplastic. It is shatter resistant and will not soften over time. It is resistant to humidity and temperatures over 300°F. Polycarbonate is virtually unbreakable, making it safe to use in areas where it may be exposed to impact.

The transparency allows the viewer to see content, read text, and see true colors through the material.

Care and Cleaning

Resistant to stains, polycarbonate is easily cleaned with common cleaner or soap and water. Alcohol is recommended to remove grease or oil. Ammonia and acetone should not be used.