



MADE  
IN THE USA

### Product Description:

- Kit Includes:
  - RS001-0412 Respiratory Hygiene Station
    - Holds two boxes of face masks, one - two boxes of facial tissues or one box of gloves, and one hand sanitizer bottle or hand sanitizing wipe canister
    - Quartz Beige Powder-Coated Steel
  - MP-075 Sign Holder - Horizontal
    - Holds 11" x 8.5" signage
    - Clear PETG Plastic
- Assembly hardware included

### Primary Area for Product Usage:

- All ports of entry
- Anywhere respiratory hygiene products are needed

### Dispenses:

- Left: Bottles no larger than 4.25"W x 4.00"D or 4.00" diameter (10.8 cm x 10.2 cm)
- Middle: Box(es) no larger than 8.00"W x 9.50"H x 4.75"D (20.3 cm x 24.1 cm x 12.1 cm)
- Right: Box(es) no larger than 5.50"W x 9.50"H x 4.75"D (13.7 cm x 24.1 cm x 12.1 cm)

### Product Specifications (overall assembled dimensions):

- 17.97"W x 20.57"H x 5.06"D (45.6 cm x 52.2 cm x 12.9 cm)
- 5.9 lbs (2.7 kg) - approximated

### Package Specifications:

- Package Quantity: 1 per case
- 20"L x 12"W x 8"H (50.8 cm x 30.5 cm x 20.3 cm)
- 8.0 lbs (3.6 kg) - approximated



Sanitizer, face masks,  
and tissues not included

### Mounting Specifications:

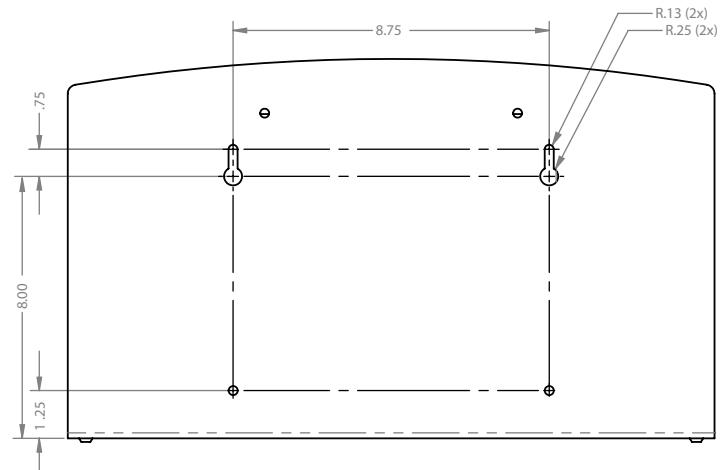

**Installation**

Always mount dispensers securely *prior* to loading with product.

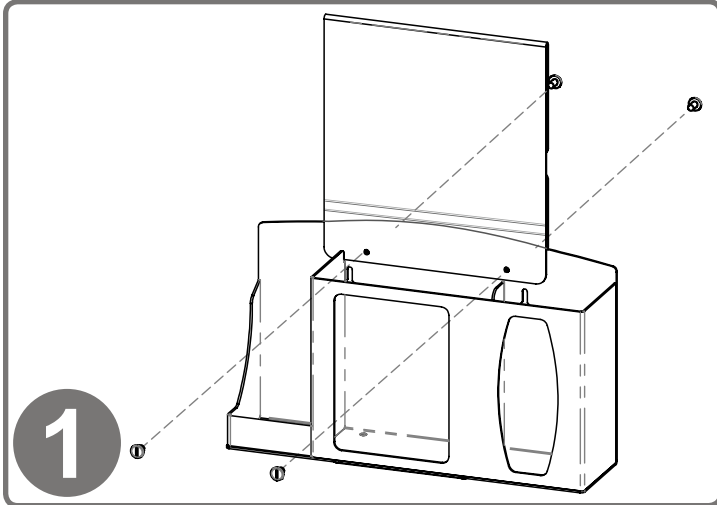

To mount the MP-075 Sign Holder, align the holes of the holder with the holes of the dispenser. With a flathead screwdriver, attach using (2x) barrel screws included with sign holder.

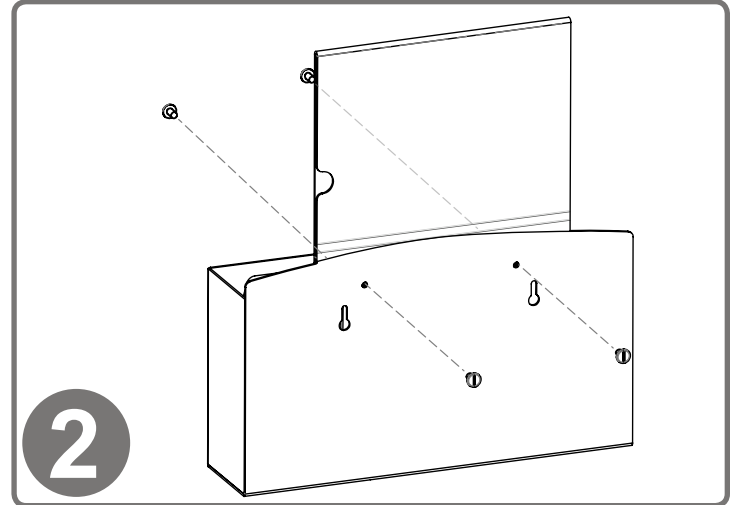

Thumb access to signage goes toward back of dispenser.

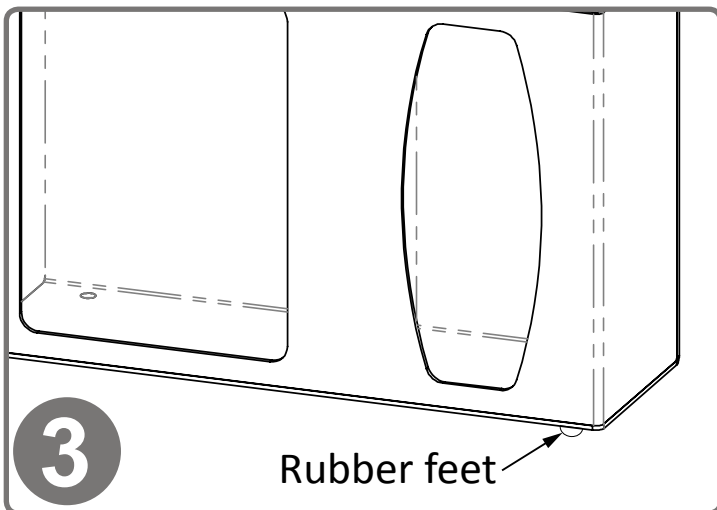

For placing on counter, attach (4x) self-adhesive rubber feet at each of the bottom corners (included).

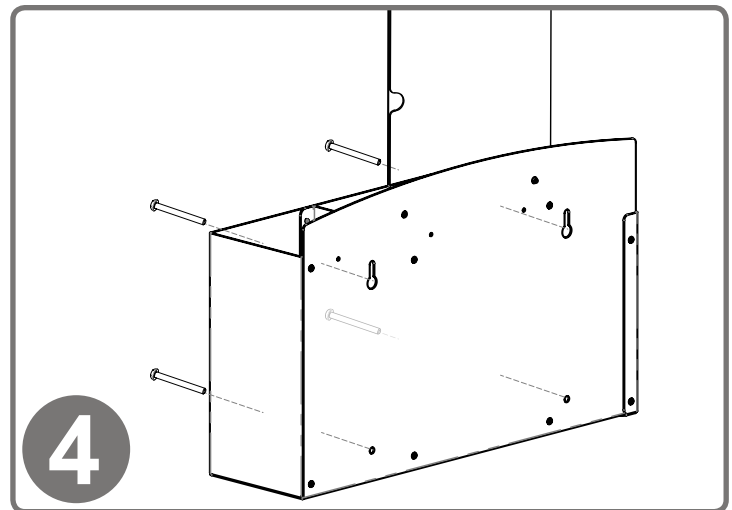

Dispenser can also be mounted securely to a wall through keyholes and screw holes in back with screws approved and supplied by building maintenance. All four mounting holes provided must be used.

**Parts included:**

- Respiratory Hygiene Station
- Sign Holder
- Hardware
  - (4x) rubber feet
  - (2x) barrel screws

**Tools Required:**

- Flathead Screwdriver

**RS001-0412**

Powder-Coated Steel

**MP-075**

PETG Plastic

**Material Characteristics****Designed for Long-Term Use**

Our steel dispensers and stands are coated with polyester powders which makes them highly resistant to corrosion.

Powder-coated steel is ideal for dispensers used in a healthcare or an industrial setting because it is impact resistant and is not effected by extremes in temperature.

Dispensers and stands made of powder-coated steel are both attractive and functional, providing years of service.

**Designed for Long-Term, Heavy-Duty Applications**

Copolyester resin is designed for heavy-duty applications, and is used by BOWMAN® Dispensers. We never use acrylic in our products.

Copolyester (PETG) is typically 15-20 times tougher than general purpose acrylic. PETG is made to withstand handling and reduce losses due to breakage.

PETG resists a variety of chemicals and commonly used cleaning agents. It is tough and durable (not brittle), providing years of trouble-free functionality and long life.

Clear optical characteristics mean the viewer can see the content, read text, and see true colors through the material. It complies with FDA regulations for food contact.

**Care and Cleaning**

For best results, clean by washing the surface with a diluted solution of a mild, non-abrasive detergent in cold or warm water and a non-abrasive cloth. Standard hospital cleaning supplies can be used.

Dry with a soft cloth. Do not use any solvent-based materials, abrasives (e.g. Scotch-brite, steel wool), or apply excessive force during cleaning.

Most cleaning chemicals do not weaken the surface or cause damage to the material. Suggested cleaning method is to use a soft cloth, warm water, and mild soap.