



MADE
IN THE **USA**

Product Description:

- Kit includes:
 - FM403-0111: Face Mask Dispenser - Locking
 - Holds contents of four - five boxes of earloop or tie face masks or other items in bulk
 - Locking pivot hinge lid
 - Top loading, bottom dispensing
 - Clear PETG Plastic
 - MP-070: Sign Holder - Vertical
 - Holds any 8.5"W x 11"H sign
 - Clear PETG Plastic
 - KS022-0020: Dual-Sided Floor Stand
 - Assembly hardware included
 - Column - Black Powder-Coated Aluminum
 - Base - Black Powder-Coated Steel

Primary Area for Product Usage:

- Anywhere public health and safety is a concern

Dispenses:

- Earloop or tie face masks

Product Specifications (overall external dimensions):

- 17.00"W x 64.56H x 17.00"D (43.2 cm x 164.4 cm x 43.2 cm)
Total height is assembled and includes sign holder
- 19.4 lbs (8.8 kg) - approximated

Mounting Specifications:

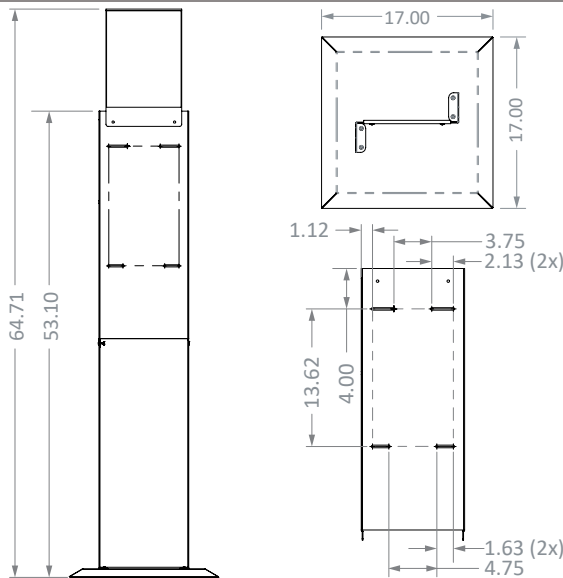

Package Specifications:

- Package Quantity: 1 per case
 - 36"L x 20"W x 6"H (91.4 cm x 50.8 cm x 15.2 cm)
 - 23.0 lbs (10.4 kg) - approximated



Face masks not
included



Installation

Always mount dispensers securely *prior* to loading with product.

- To secure base to column, place column over base (top of base is raised side).
- Using a wrench/pliers and screwdriver, attach all four screws (10-32 x 5/16") with the included nylock nuts. Tighten.

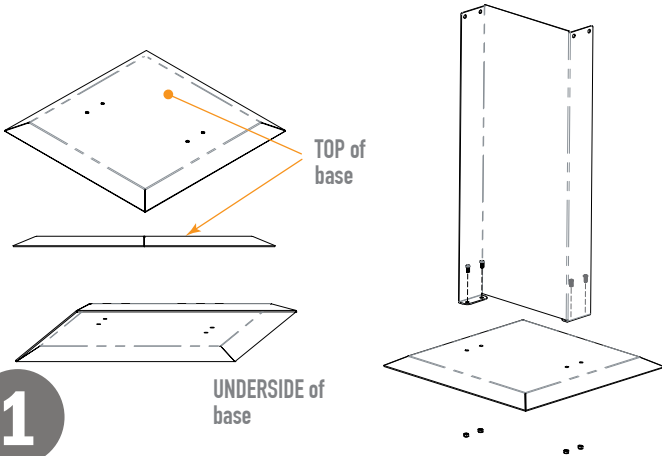

- Attach the top piece to the bottom assembly using 4 sets of the barrel screws.

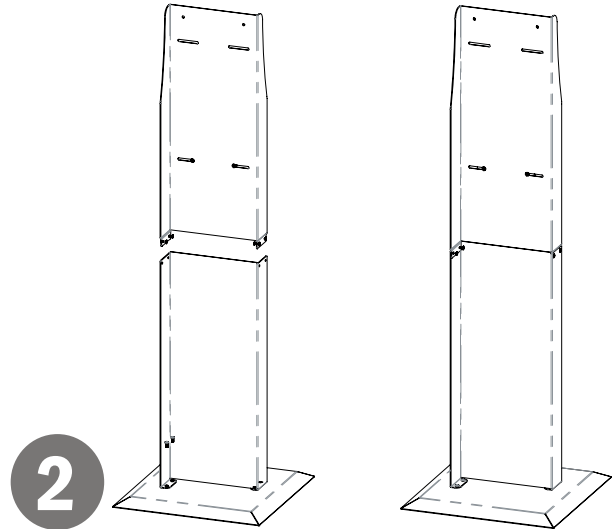

- Attach sign holder using 2 sets of barrel screws.
- Insert signage.

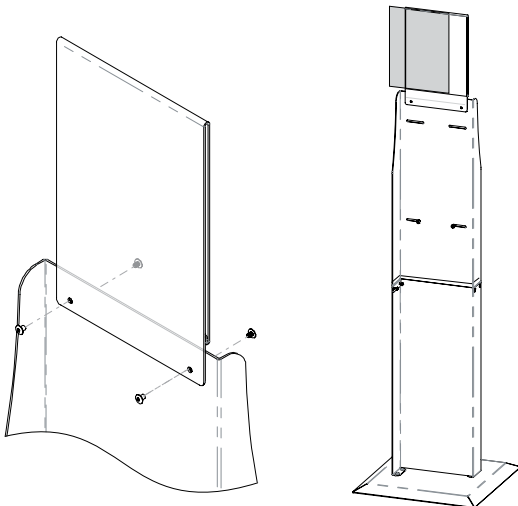

- Mount empty FM403-0111 by first connecting barrel screws through slots.
- Next, hang FM403-0111 onto barrel screws and tighten.

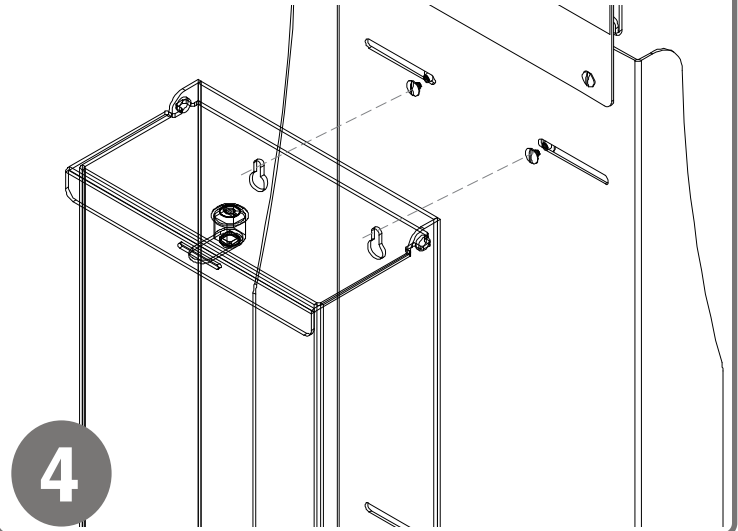

Parts included:

- Floor Stand Base
- Floor Stand Column (2 pieces)
- Face Mask Dispenser
- Sign Holder

- Hardware
 - (4x) Screws (Phillips type 10-32 x 5/16")
 - (4x) Nylock nuts (10-32)
 - (8x) Sets of barrel screws

Tools Required:

- Phillips and Flathead screwdrivers
- Pliers, adjustable wrench, or 3/8" wrench



Optional Installation

Always mount dispensers securely *prior* to loading with product.

Mounting a dispenser with VHB tape

- Mount additional, empty FM403-0111 or other bulk dispenser with VHB tape (sold separately) according to mounting procedures listed below.
- See BD119-0000 Dispenser Cross Reference for compatible dispensers.

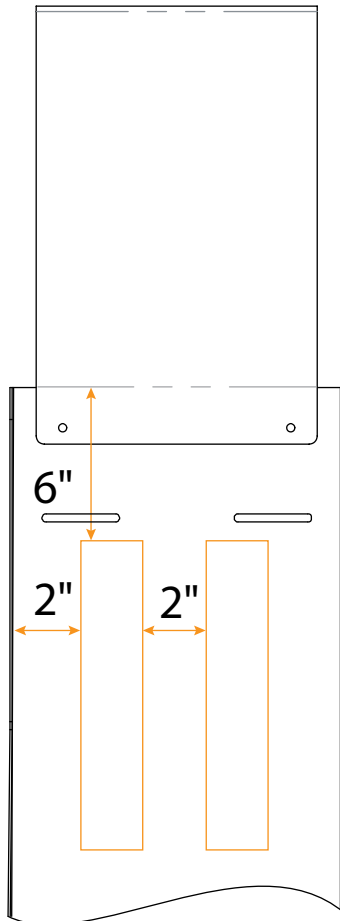
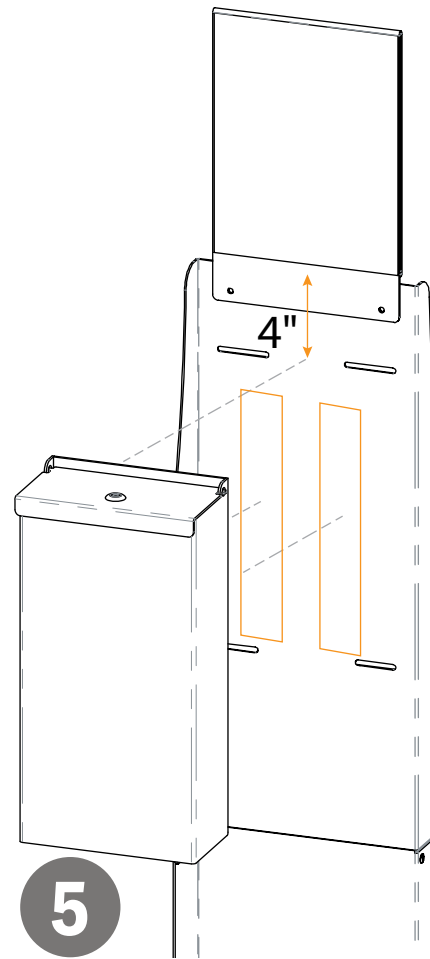
**2****5**

Proper Mounting Procedure:

- 1) Clean the mounting surface of the floor stand using a mixture of 50:50 isopropyl alcohol and water prior to mounting the dispenser.
- 2) Allow surface to dry completely. Remove the backing from both tape strips, place vertically as illustrated and press firmly to adhere tape to surface.
- 3) Allow adhesive a *minimum of 24 hours to set prior to mounting a BOWMAN® dispenser to the stand. (*Tape is fully cured after 72 hours.)
- 4) Clean back of dispenser as in #1.
- 5) Remove backing from tape strips and press the empty dispenser firmly to the floor stand to adhere.
- 6) Allow to cure for at least 24 hours.
- 7) Load consumables.
- 8) The tape is rated to hold a maximum of 5 lbs. when mounted.
- 9) Removal of product is not advised as damage to product surfaces could occur.



KS022-0020 Column
Powder-Coated Aluminum

KS022-0020 Base
Powder-Coated Steel

FM403-0111 & MP-070
PETG Plastic

Material Characteristics

Designed for Long-Term Use

Our powder-coated aluminum dispensers resist corrosion, chipping, and flaking. It is lightweight, yet high in strength. This material will provide long-lasting products that hold up well, even in tough environments.

Powder-coated aluminum is ideal for dispensers used in a healthcare or industrial settings. It is impact resistant and is not affected by extremes in temperature.

Dispensers made of powder-coated aluminum are clean, bright, and attractive, creating a professional appearance.

Designed for Long-Term Use

Our steel dispensers and stands are coated with polyester powders which makes them highly resistant to corrosion.

Powder-coated steel is ideal for dispensers used in a healthcare or an industrial setting because it is impact resistant and is not effected by extremes in temperature.

Dispensers and stands made of powder-coated steel are both attractive and functional, providing years of service.

Designed for Long-Term, Heavy-Duty Applications

Copolyester resin is designed for heavy-duty applications, and is used by BOWMAN® Dispensers. We never use acrylic in our products.

Copolyester (PETG) is typically 15-20 times tougher than general purpose acrylic. PETG is made to withstand handling and reduce losses due to breakage.

PETG resists a variety of chemicals and commonly used cleaning agents. It is tough and durable (not brittle), providing years of trouble-free functionality and long life.

Clear optical characteristics mean the viewer can see the content, read text, and see true colors through the material. It complies with FDA regulations for food contact.

Care and Cleaning

For best results, clean by washing the surface with a diluted solution of a mild, non-abrasive detergent in cold or warm water and a non-abrasive cloth. Standard hospital cleaning supplies can be used.

Dry with a soft cloth. Do not use any solvent-based materials, abrasives (e.g. Scotch-brite, steel wool), or apply excessive force during cleaning.

Most cleaning chemicals do not weaken the surface or cause damage to the material. Suggested cleaning method is to use a soft cloth, warm water, and mild soap.