

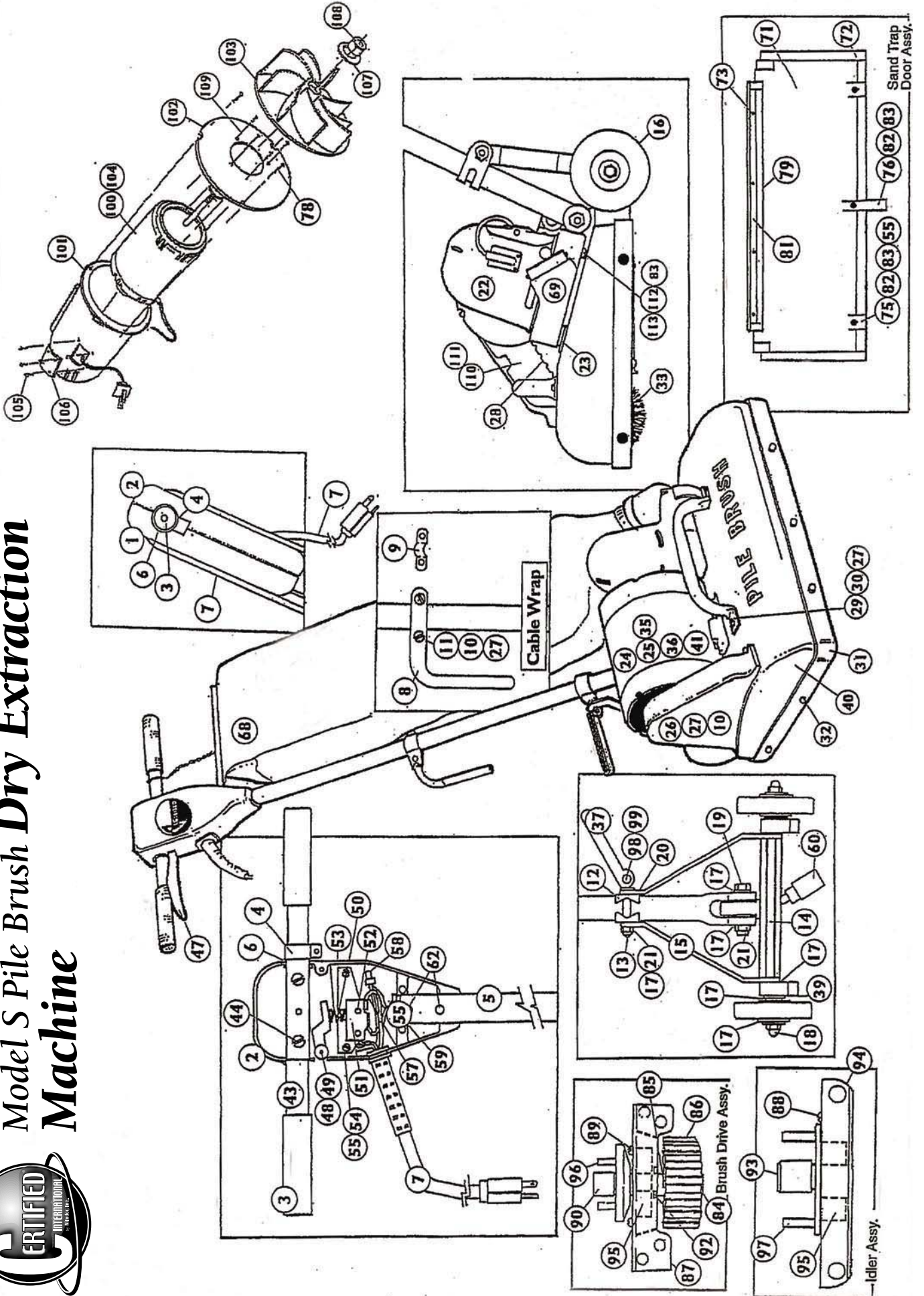

# Model S Pile Brush Dry Extraction Machine





**CERTIFIED MODEL "S" PILE BRUSH PARTS LIST**

<b>Drawing Number</b>	<b>Part Number</b>	<b>Description</b>	<b>Number Required</b>
	<b>101-002</b>	<b>PILE BRUSH HANDLE ASSEMBLY INCLUDES (101-014) FLOOR ROD CLAMP ASSEMBLY</b>	
1.	900-078	Switch Box Cover Casting	1
2.	900-077	Switch Box Back Casting (has 3 thru holes)	1
	**905-002	Bottom Switch Box Screw	2
	**905-019	Top Switch Box Screw	1
3.	929-006	Plastic Handle Grip	2
4.	946-005	Dust Bag Support Ring	1
5.	957-008	2" Floor Rod & Yoke	1
6.	938-001	Plastic Handle Bushing	2
7.	921-041	Power Cable w/Plug	1
8.	915-051	Cable Wrap	1
9.	915-052	Cable Wrap Clamp	1
10.	903-007	1/4-20 x 3/4 Rd. Hd. Screw	2
11.	908-004	1/4-20 Hex Nut	2
43.	930-008	Handle Bar	1
44.	904-034	Handle Bar Screws 1/4-20 x 1-1/2	2
47.	900-092	Switch Lever Casting	1
48.	901-016	3/16 x 1-1/2 Spiral Pin	2
49.	907-023	3/16 id Spiral Pin Washer	1
50.	946-010	Motor Drive Switch Auxiliary Spring	1
51.	920-008	Motor Drive Switch	1
52.	903-015	Motor Drive Switch Screws	2
53.	915-036	Motor Drive Mounting Bracket	1
54.	903-020	10-32 x 3/8 Rd. Hd. Screw - S	3
55.	906-004	#10 Lock Washer	2
57.	922-062	#10 Butt Wire Connector	1
58.	922-060	Acorn Nut Wire Connector	1
59.	913-002	3/8 x 1/2 Strain Relief Tubing	1
60.	921-009	Floor Rod Electric Cable w/Plug	1
62.	910-002	Allen Head Cap Screw	2
19.	910-005	Floor Rod Base Bolt	1
17.	907-002	3/8 Wrought Steel Washer - Small	2
21.	908-002	3/8-16 Essna Lock Nut	1
27.	906-001	1/4" Lock Washer	2
	<b>101-014</b>	<b>2" FLOOR ROD CLAMP ASSEMBLY</b>	
12.	900-147	2" High Floor Rod Clamp Casting (for 1-1/4" dia.)	1
13.	902-001	Cam Thrust Bolt	1
20.	907-009	3/8 Wrought Steel Washer	1
21.	908-002	3/8-16 Essna Lock Nut	1
37.	915-003	Clamp Cam Lever	1
98.	902-002	5/16-18 x 1 Clamp Cam Lever Bolt	1
99.	908-005	5/16-18 Clamp Cam Lever Lock Nut	1
17.	907-002	3/8 Wrought Steel Washer - Small	1

\*\*INDICATES NOT ILLUSTRATED

**CERTIFIED MODEL "S" PILE BRUSH PARTS LIST**

<b>Drawing Number</b>	<b>Part Number</b>	<b>Description</b>	<b>Number Required</b>
	<b>101-016</b>	<b>AXLE ASSEMBLY</b>	
14.	943-001	Axle	1
16.	927-010	4" Non-Marking Wheels (3/8 i.d.)	2
17.	907-002	3/8 Flat Washer	6
18.	942-004	Axle Hub Cap	2
	**939-024	Large Axle X Ring	2
	**939-023	Small Axle X Ring	2
<b>68.</b>	<b>924-024</b>	<b>ZIPPER BAG - TOP FILL (HIGH EFFICIENCY)</b>	
	**924-058	High Efficiency Paper Bag Inserts 3/pkg (fits #924-024 bag only)	1
	**924-056	Paper Bag Inserts 3/pkg. (fits bottom fill bag only)	1
	**946-011	Paper Bag Support Ring	1
	**924-002	Shake Down Dust Bag	
	**935-001	Clamp, Chain & Hook Assem. (for original shake down bag)	
	<b>101-004</b>	<b>BASE WITH BUMPER ASSEMBLY</b>	
40.	900-009	Polished Base Casting w/939-004 helicoils	1
31.	928-009	Plastic Bumper	1
32.	913-001	Nylon Bumper Rivets	9
	<b>101-007</b>	<b>BRUSH DRIVE SHAFT BEARING &amp; HOLDER ASSEMBLY</b>	
84.	939-002	Drive Shaft Pulley Snap Ring	1
85.	939-003	Brush Drive Shaft Pulley Key	1
86.	936-003	Brush Drive Pulley	1
87.	900-007	Drive Shaft Bearing Holder Casting	1
89.	903-001	8-32 x 1/4 Rd. Hd. Screw	2
90.	936-002	Brush Drive Shaft	1
96.	901-025	1/4 x 3/4 Spiral Pin	2
95.	937-001	Drive Bearing	1
92.	939-001	Drive Bearing Snap Ring	1
	**903-018	1/4-20 x 1-1/2" Rd. Hd. M/S (Holds 900-007	1
	**903-019	1/4-20 x 1-5/8" Rd. Hd. M/S in place)	3
	<b>101-009</b>	<b>IDLER SHAFT BEARING &amp; HOLDER ASSEMBLY</b>	
93.	936-004	Brush Idler Shaft	1
94.	900-008	Idler Bearing Holder Casting	1
95.	937-001	Idler Bearing	1
97.	901-025	1/4 x 3/4 Spiral Pin	2
88.	903-004	6-32 x 1-1/4 Rd. Hd. Screw	1
	**903-019	1/4-20 x 1-5/8" Rd. Hd. M/S (Holds 900-008 in place)	2
	<b>101-013</b>	<b>SAND TRAP DOOR ASSEMBLY</b>	
	**901-003	7/8 Spiral Pin for Right Side Hinge & Sand Trap Spring	3
71.	915-005	Sand Trap Door Stamping	1
72.	914-012	Sand Trap Door Foam Tape Gasket, 26"	1
73.	913-008	1/8 x 7/16 Semi-Tubular Rivet	4
	**901-004	1-1/8 Spiral Pin for Left Side Hinge	1
75.	942-002	Spring Clamp	2
76.	942-003	Finger Lift	1
79.	928-012	Plastic Cigarette Catch	1
81.	915-006	S.S. Reinforcing Strip	2
82.	903-006	Spring Clamp Screw	2
	903-009	Finger Lift Screw	1
83.	908-003	Spring Clamp & Finger Lift Nut	3
112.	906-004	#10 Lock Washer "S"	3

\*\*INDICATES NOT ILLUSTRATED

**CERTIFIED MODEL "S" PILE BRUSH PARTS LIST**

<b>Drawing Number</b>	<b>Part Number</b>	<b>Description</b>	<b>Number Required</b>
22.	101-102	<b>VACUUM MOTOR ASSEMBLY (115V)</b>	1
100.	916-102	Vacuum Motor w/Pig Tail Only (115V)	1
101.	1-871001-000	Motor Housing	1
102.	932-052	Vac Motor Mount Plate	1
103.	1-608005-000	Fan	1
78.	911-009	Self Tapping Screw	3
105.	903-001	#8-32 x 1/4 Screw	4
106.	915-224	Cover, Strain Relief	1
107.	907-056	Washer Shims	a.r.
108.	908-026	Nut - Left Hand 5/16-24	1
109.	903-080	#10-32 x 1/4 Pan Hd. Screw	4
22.	101-112	<b>VACUUM MOTOR ASSEMBLY (220V)</b>	1
104.	916-112	Vacuum Motor w/Pig Tail Only (220V)	1
101.	1-871001-000	Motor Housing	1
102.	932-052	Vac Motor Mount Plate	1
103.	1-608005-000	Fan	1
78.	911-009	Self Tapping Screw	4
105.	903-001	#8-32 x 1/4 Screw	4
106.	915-224	Cover, Strain Relief	1
107.	907-056	Washer Shims	a.r.
108.	908-026	Nut - Left Hand 5/16-24	1
109.	903-080	#10-32 x 1/4 Pan Hd. Screw	4
		<b>MISCELLANEOUS PARTS</b>	
15.	915-004	Angle Support	2
33.	945-082	Vegetable Fibre Brush	1
33.	945-005	Nylon Tufted Brush	1
23.	914-056	Vacuum Motor Gasket	1
24.	916-049	Brush Drive Motor (115V, 60Hz)	1
24.	916-095	Brush Drive Motor (220V, 50Hz)	1
25.	910-046	5/16-18 x 3/4 Motor Mount Bolt	4
26.	900-014	Belt Guard Casting	1
27.	906-001	1/4 Lock Washer	a.r.
10.	903-007	1/4-20 x 3/4 Rd. Hd. Screw	a.r.
28.	941-001	Timing Belt	1
29.	923-005	Chromed Handle	1
30.	903-027	1/4-20 x 1/2 Rd. Hd. Screw	a.r.
35.	936-001	Drive Motor Pulley w/912-002 Set Screws	1
36.	907-035	5/16 Motor Mount Flat Washer	4
41.	906-015	5/16 Lock Washer	4
110.	915-215	Shield - Belt Guard	1
111.	903-001	#8-32 x 1/4" Hd. Screw	2
69.	2-015410-000	Fan Case	1
83.	908-003	#10-24 Nut (Fan case to base)	3
55.	906-004	#10 Lock Washer (Fan case to base)	3
113.	904-049	#10-24 x 5/8 Lg. Flat Hd. Screw (Fan case to base)	3

\*\*INDICATES NOT ILLUSTRATED

a.r. - as required

CERTIFIED reserves the right to make changes and improvements in design and construction.

Please furnish the Serial Number of the machine for which parts are required so we may furnish the proper or equivalent replacements if available.