

17LS3-SS, 17LS3-BK  
20LS3-SS, 20LS3-BK  
20DS3-SS  
17LS4-Bk, 20LS4-BK

# LOW SPEED AND DUAL SPEED FLOOR MACHINE

OWNER'S/OPERATOR'S MANUAL

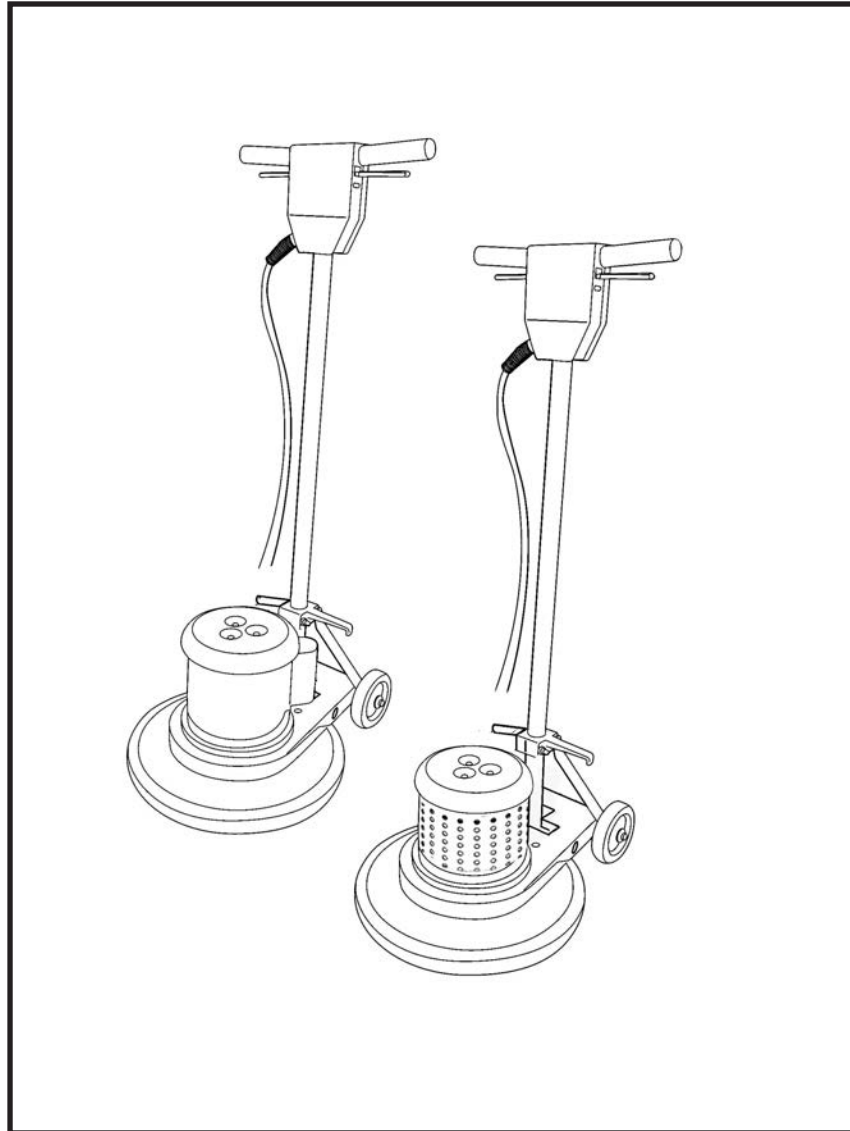

[www.UNOCLEAN.com](http://www.UNOCLEAN.com)

224-654-6500

## UNPACKING YOUR NEW SATURN:

When your package is delivered, check each of the 3 cartons carefully for signs of rough handling. If the SATURN is damaged, notify the carrier immediately and request an inspection. Be sure to keep the cartons, packing inserts, packing lists and carrier's receipt until the inspector has verified your claim.

EDIC's liability ceases when the carrier picks up the shipment. However, our customer service staff will be happy to furnish any information needed in connection with the claim and will attempt to expedite a resolution.



## PLEASE READ BEFORE OPERATING YOUR NEW SATURN:

Read the manual carefully and completely before attempting to operate the unit. This manual has important information for the use and safe operation of the machine. Keep this manual handy at all times.

This equipment has been engineered and manufactured to provide excellent performance and service. To ensure that your equipment will continue to perform as intended:

- Maintain and inspect equipment regularly
- Use only original EDIC parts when servicing.
- Operate equipment with care.

If additional information is needed, please contact EDIC at: 800-338-3342 or email [info@edic-usa.com](mailto:info@edic-usa.com)

All information and specifications printed in the manual are current at the time of printing; however, because of EDIC's policy of continual product improvement, we reserve the right to make changes at any time without notice.

## FAILURE TO COMPLY WITH THE FOLLOWING WARNINGS AND INSTRUCTIONS WILL VOID THE WARRANTY.

## WARNING!

- Do not operate the machine unless trained and authorized.
- Do not leave the machine unattended when plugged in. Unplug from the outlet when not in use, before servicing, and when changing the brushes or pads.
- Use indoors only.
- Do not allow to be used as a toy. Close attention is necessary when used by or near children.
- Do not bypass or defeat the safety "lock-out lever."
- The machine was designed for use as per instructions and recommendations written in this manual. Any deviation from its proper use or purpose and the consequential damage that may occur is the sole responsibility of the end user.
- Do not use with damaged cord or plug. If the machine is not working as it should, or it has been dropped, damaged, left outdoors or dropped into water, take it to an authorized service center.
- Do not pull or carry by cord, use cord as handle, close a door on the cord or pull cord around sharp edges or corners. Do not run machine over cord. Keep cord away from heated surfaces.
- Do not unplug by pulling on cord. To unplug, grasp the plug, not the cord.
- Do not handle plug or appliance with wet hands.
- Make sure the machine is plugged into an electrical outlet with the same voltage and frequency rating as shown on the nameplate of the machine. Do not attempt to plug a 115- volt machine into a 230- volt outlet.
- Do not immerse or use this machine in standing water. Such use can cause electric shock.
- Keep the electrical supply cord from contacting the rotating brush or drive block.
- Do not expose machine to freezing temperatures.
- To avoid electric shock, do not expose the unit to rain. Store indoors only.
- Connect to a properly grounded outlet only. See "Grounding Instructions."
- Turn off all controls before unplugging.
- When using an extension cord, use a 3 conductor-grounding cord, 12 gauge wire or heavier. Do not use more than 25' of extension cord.
- Do not put any object into openings.
- Do not use with any opening blocked. Keep free of dust, lint, hair and anything that may reduce air flow.
- Do not operate machine in flammable or explosive areas.
- All servicing of EDIC equipment should be per-

- formed by an EDIC authorized service center.
- Keep hair, loose clothing, fingers and all parts of body away from openings and moving parts.
- Use extra care when cleaning near stairs.
- When servicing machine, use manufacturer's supplied or approved replacement parts.
- Do not wrap the cord too tightly when storing.
- Work only in well lit areas.
- This equipment is heavy. Use proper lifting techniques when lifting heavy equipment.

### GROUNDING INSTRUCTIONS:

This piece of equipment must be grounded. Should an electrical malfunction occur, grounding provides a path of least resistance for electrical current- reducing the risk of electric shock. This piece of equipment is furnished with a cord that has a grounding conductor and grounding plug. The grounded plug must only be plugged into an appropriate outlet that is properly installed and grounded in accordance with all local codes and ordinances.

### WARNING:

Connecting the equipment to an improperly grounded outlet can result in an increased risk of electric shock. A qualified electrician should be consulted if you are unsure that the outlet is properly grounded. Do not modify the plug provided with the equipment. If it will not fit the outlet, have a proper outlet installed by a qualified electrician.

This appliance is designed for use on a 120-volt circuit. The grounding plug provided looks like the plug illustrated in Figure 1. Replace the plug if the grounding pin is damaged or broken.

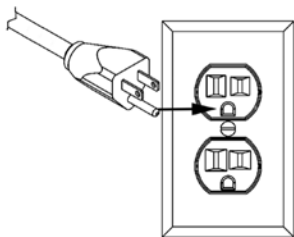

Figure 1

The Green (or Green/Yellow) wire in the cord is the grounding wire. When replacing a plug, this wire must be attached to the grounding pin only.

DO NOT use extension cords.

### Servicing:

In the event that your SATURN requires service, please contact EDIC at:

800-338-3342

or email [info@edic-usa.com](mailto:info@edic-usa.com)

Do not attempt repairs yourself. EDIC will assist you in locating an independent service contractor.

### PREPARING THE MACHINE FOR OPERATION

Your floor machine will operate in a wide variety of hard floors and carpet cleaning applications. Consult with your local dealer or EDIC Customer Service to select the correct accessories for the job you are going to perform.

### BRUSH, PAD DRIVER INSTALLATION

Lock the handle in the upright position and tip the machine back so it rests on the handle and wheels. Fit the three slots of the clutch plate in the back of the brush or pad driver over the three lugs of the drive plate (Fig. 1). Push it firmly into position and turn it counterclockwise until it locks in place (Fig. 2).



Fig. 1

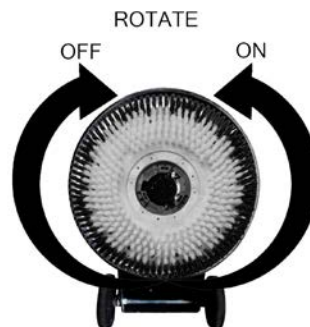

Fig. 2

---

### **TO REMOVE PAD DRIVER:**

Tip the machine back so it rests on the handle and wheels. Turn the brush or pad driver clockwise until it disengages and lifts off. Do not store the machine with the brush or pad drivers installed.

### **PAD INSTALLATION**

**TO INSTALL PAD:** Tilt the machine back on wheels until machine is resting on handle. Center the pad on the pad holder and press the pad onto the pad holder.

**TO REMOVE PAD:** Simply remove the pad from the pad holder by pulling it away from the pad holder with steady force.

### **MACHINE OPERATION**

1. Install the pad driver and pad, brush or attachment.
2. Plug in machine.
3. Lower the handle to the desired operating position.
4. Place both hands on the handle grips with your fingers around the ON/OFF lever which extends from one side to the other underneath the handle grips.
5. The safety LOCK-OUT lever is located underneath the right side handle grip and ON/OFF lever. To unlock the LOCK-OUT lever, use your right hand forefinger to press the lever down toward the back of the switch box
6. While pressing the LOCK-OUT lever, pull the ON/OFF lever on either side of the handle to start the machine.
7. The LOCK-OUT lever will automatically lock when you release the ON/OFF lever preventing the machine from being turned on until it is unlocked again.

### **TO MANEUVER YOUR FLOOR MACHINE**

1. Raise the handle slightly and the machine will go to the right. The higher you raise it, the faster it will go.
2. Lower the handle and the machine will go left. The more you lower it, the faster it will go.
3. Practice on a smooth surface to gain experience in operating the unit before moving on to other surfaces.

### **DUAL SPEED FUNCTION FOR 17DS3-BK & 20DS3-BK:**

Use the black switch located directly behind the motor to switch between low speed (180RPM) and high speed (320RPM). Do not change speeds while machine is run-

ning. Always wait until motor has stopped completely before changing speeds.

### **Storage:**

Wipe with a clean damp cloth after every use. Store in a clean dry place.

### **CORD STORAGE:**

- Unplug the cord- Clean and inspect for damage.
- Wrap the cord around the left side handle grip.
- Do not wrap too tightly.

---

# NOTES

# LOW SPEED WIRING

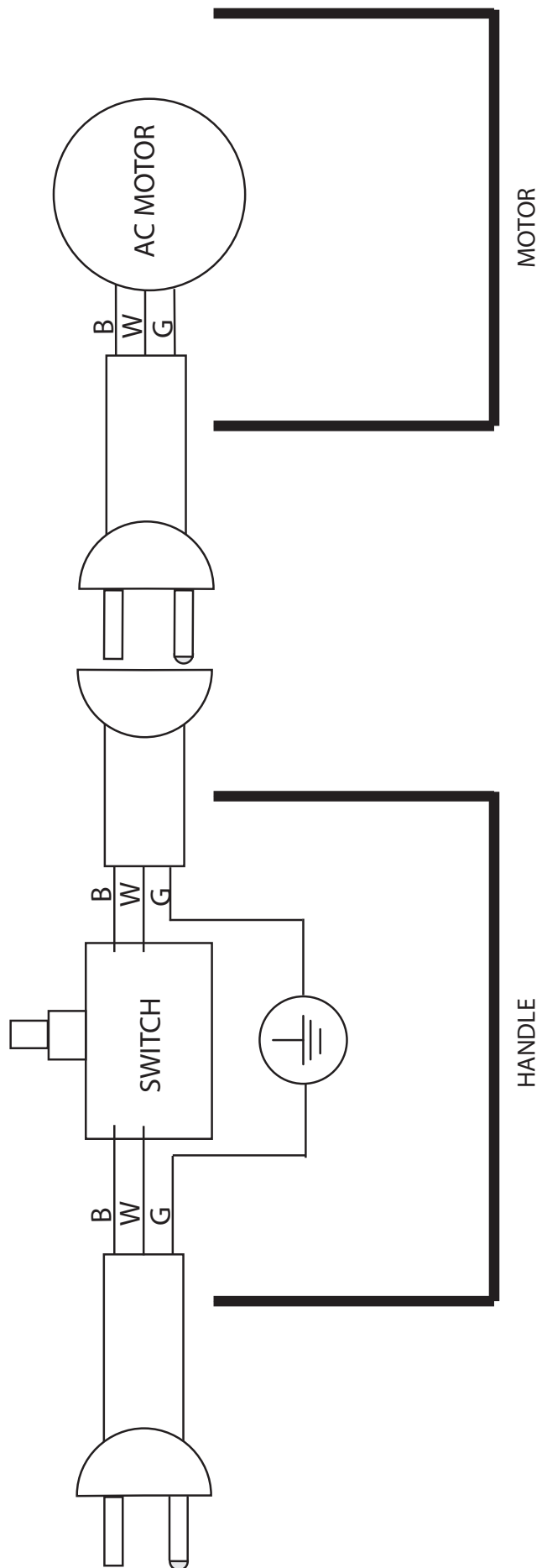

# DUAL SPEED WIRING

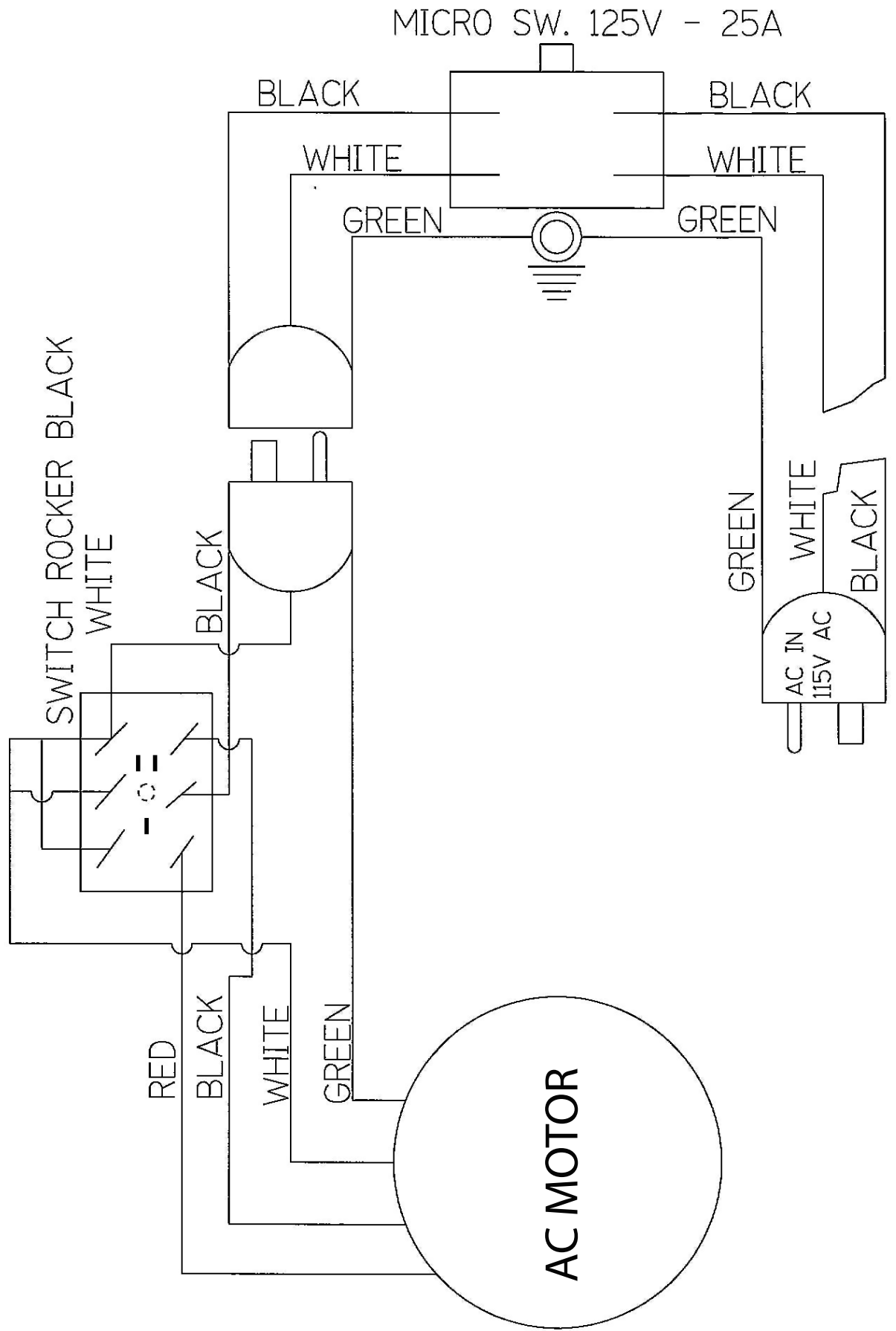

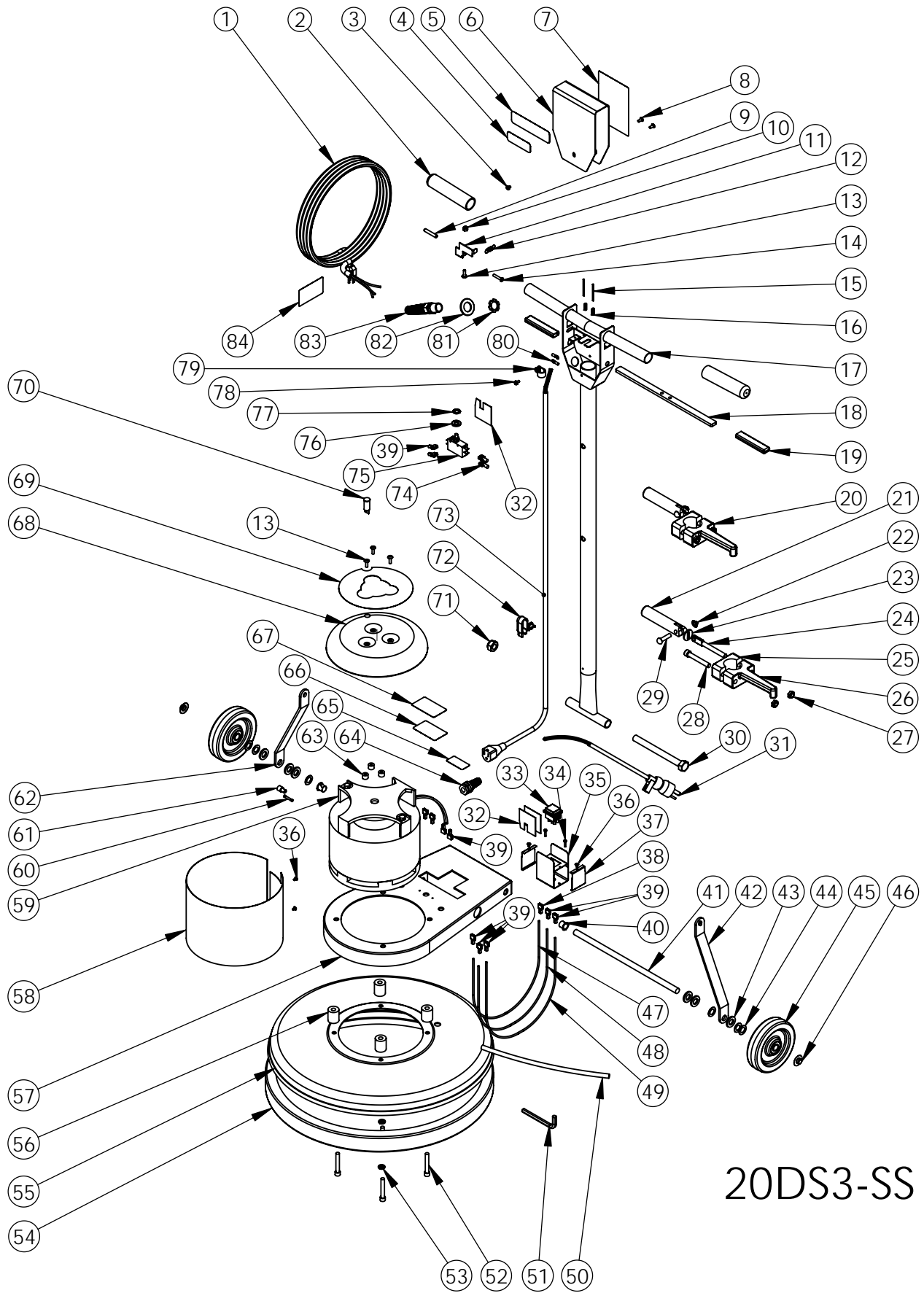

20DS3-SS



# 20DS3-SS

ITEM NO.	PART NUMBER	DESCRIPTION	QTY.
1	B11487 Power Cord, 14-3, 50 FT, SJTW		1
2	K11498 Grip		2
3	C11528 Screw, 10-32 X .25 in		1
4	H12066 Label, 0.5 HP, Saturn		1
5	H11831 Label, EDIC, Black-Silver		1
6	D11496B Switch Box Cover, Black		1
7	H11493 Label, Safety, Floor Machine		1
8	C11529 Screw, 10-32 X .375 in		2
9	K11519 Lever Grip, Lockout, Black		1
10	C00278 Locknut, 10-32, Nylon, SS		1
11	D11494 Lockout Bracket		1
12	D11524 Spring, Lockout		1
13	C90007 Screw, 10-32 X .625 Phillips, Truss Head, SS		4
14	C11491 Screw, 10-32 X 1 in, SS		1
15	C00306 Roll Pin, .125 X 1.75		2
16	D11523 Spring, Trigger		2
17	D11479 Handle, Chrome, Floormachine		1
18	D11495 Trigger, Zinc Plated		1
19	K11520 Lever Grip, Trigger, Black		2
20	11507A Assembled Locking Handle, Cord Hook		1
21	D11497 Handle, Locking Clamp		1
22	C11538 Cap Nut, .31 in, Push-On		1
23	C00259 Washer, Slotted, Zinc		1
24	C11536 Spade Bolt, .375-16 X 4 in		1
25	D11507 Cord Hook Clamp		1
26	D11507-2 Cord Hook Body		1
27	C11558 Locknut, .375-16, Nylon		2
28	C11502 Socket Cap Screw, .375-16 X 2.5 in		1
29	C11537 Dowel Pin, .31 X 1.5 in		1
30	C13101 Screw, Hex Cap, M14-2.0		1
31	B10719 Power Cord, 25', 16-3		1
32	B11518 Switch Insulation		3
33	B11751 Switch, Rocker, DPDT, Black		1
34	C00293 #8 X .5in Pan, Black SMS, Phillips		2
35	D11582 Bracket, Switch Mount		1
36	C00297 Screw #8 X .25 in, Pan Head		4
37	D11646 Switch Bracket Cover		2
38	B00177-1 Terminal Lug, Female, OD, .25 X .032		1
39	B00177 Terminal Lug, Female, OD, .25 X .032		11
40	K00674 Bushing, .50 in, Nylon		2
41	D11510 Axle, Floor Machine		1
42	D11482 Handle Brace, Right, Black		1
43	C00240 Washer, Shoulder, Nylon		6
44	C11559 Washer, .515 X .875 X .032		6
45	G11943 Wheel, 5 in Saturn		2
46	C02305 Cap Nut, .5in Push-on		2
47	B00185-30 Wire, 14 Ga X 2 ft, White, UL195		1
48	B00185-40 Wire, 14 Ga X 2 ft, Black, UL1015		1
49	B00185-86 Wire, 14 Ga X 2 ft, Red, UL1015		1
50	B00228-2 1 Foot Shrinktube, .375 in, Poly		1
51	C11619 Allen Wrench, .31 in		1
52	C11501 Socket Cap Screw, .31 - 18		4
53	C00251 Lockwasher, .31, Split		4
54	E11478 Bumper, 20 in Floor Machine		1
55	D11486-SS Brush Cover, 20 in, Stainless		1
56	K11521 Spacer, Base, Floor Machine		4
57	D11483 Frame, Motor, Black		1
58	D11545 Motor Screen		1
59	G11573 Motor		1
60	B00181 Butt Connector, Blue, 1 Wire		1
61	B00179-1 Closed End Cntr, 16-3		1
62	D11481 Handle Brace, Left, Black		1
63	K11517 Spacer, .19 ID X .375 High X .50 OD, Nylon		3
64	B11199 Strain Relief, Pigtail w-Locknut		1
65	H10976-1 Label, UL STD 561-507		1
66	H00565-5 Label, Serial #, Standard		1
67	H03545 Cover, Serial #, Label		1
68	H11490C-H Drip Cover w - Light, Chrome		1
69	H11830 Label, Saturn, Drip Cover		1
70	B02196-1 Light, Motor Carbon Brush Wear		1
71	C13100 Nut, M14-2.0 Nylon Insert		1
72	B10734 Strain Relief, Handle		1
73	B11513 Cord, Handle, 14-3 SJTW		1
74	B11762 Terminal Lug, Nylon, Female		2
75	B11465 Switch, DPST, Pushbutton		1
76	C00252 Washer, .375 in, Flat		1
77	C11541 Washer, .375 in, Star		1
78	C00284 Screw, 10-32 X .375 Ground		1
79	B00187 Cable Clamp, Nylon, .43 in.		1
80	B00180-10-3 Ring Terminal, #10 Center		2
81	B11505 Strain Relief Nut, Metal		1
82	C11560 Washer, .93 ID X 1.5 OD		1
83	B11504 Strain Relief, Metal		1
84	H02548-2 Label, Important, Cord		1

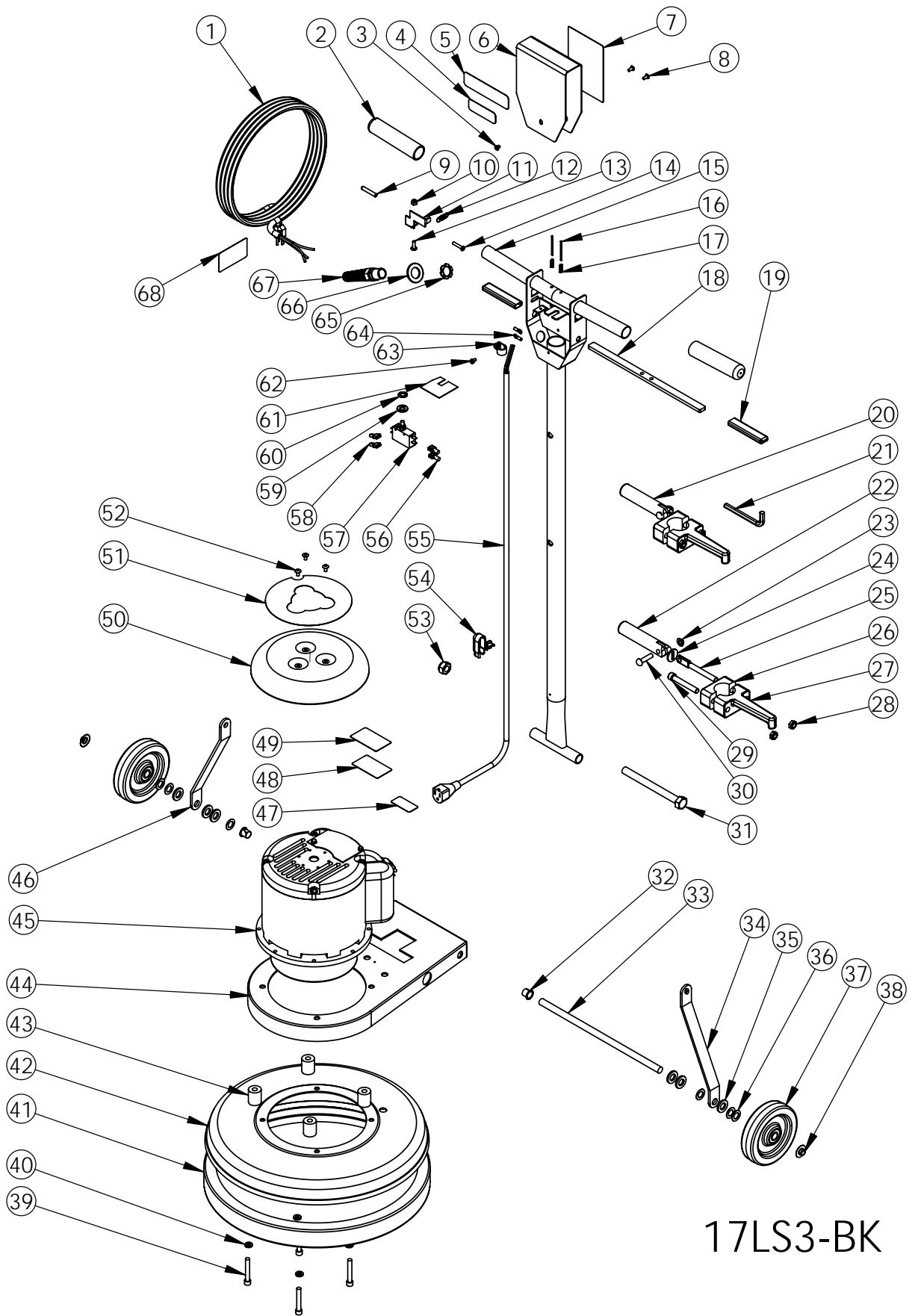

17LS3-BK

# 17LS3-BK

ITEM NO.	PART NUMBER	DESCRIPTION	QTY.
1	B11487	Power Cord, 14-3, 50 FT, SJTW	1
2	K11498	Grip	2
3	C11528	Screw, 10-32 X .25 in	1
4	H12066	Label, 1.5 HP, Saturn	1
5	H11831	Label, EDIC, Black-Silver	1
6	D11496B	Switch Box Cover, Black	1
7	H11493	Label, Safety, Floor Machine	1
8	C11529	Screw, 10-32 X .375 in	2
9	K11519	Lever Grip, Lockout, Black	1
10	C00278	Locknut, 10-32, Nylon, SS	1
11	D11494	Lockout Bracket	1
12	D11524	Spring, Lockout	1
13	C90007	Screw, 10-32 X .625 Phillips, Truss Head, SS	1
14	C11491	Screw, 10-32 X 1 in, SS	1
15	D11479	Handle, Chrome, Floormachine	1
16	C00306	Roll Pin, .125 X 1.75	2
17	D11523	Spring, Trigger	2
18	D11495	Trigger, Zinc Plated	1
19	K11520	Lever Grip, Trigger, Black	2
20	11507A	Assembled Locking Handle, Cord Hook	1
21	C11619	Allen Wrench, .31 in	1
22	D11497	Handle, Locking Clamp	1
23	C11538	Cap Nut, .31 in, Push-On	1
24	C00259	Washer, Slotted, Zinc	1
25	C11536	Spade Bolt, .375-16 X 4 in	1
26	D11507	Cord Hook Clamp	1
27	D11507-2	Cord Hook Body	1
28	C11558	Locknut, Black Oxide, Thin	2
29	C11502	Socket Cap Screw, .375-16 X 2.5 in	1
30	C11537	Dowel Pin, .31 X 1.5 in	1
31	C13101	Screw, Hex Cap, M14-2.0	1
32	K00674	Bushing, .50 in, Nylon	2
33	D11510	Axle, Floor Machine	1
34	D11482	Handle Brace, Right, Black	1
35	C00240	Washer, Shoulder, Nylon	6
36	C11559	Washer, .515 X .875 X .032	6
37	G11943	Wheel, 5 in Saturn	2
38	C02305	Cap Nut, .5in Push-on	2
39	C11501	Socket Cap Screw, .31 - 18	4
40	C00251	Lockwasher, .31, Split	4
41	E11477	Bumper, 17 in Floor Machine	1
42	D11485B	Brush Cover, 17 in, Black	1
43	K11521	Spacer, Base, Floor Machine	4
44	D11483	Frame, Motor, Black	1
45	G11468	Motor W-Gearbox, 1.5 HP	1
46	D11481	Handle Brace, Left, Black	1
47	H10976-1	Label, UL STD 561-507	1
48	H00565-5	Label, Serial #, Standard	1
49	H03545	Cover, Serial #, Label	1
50	D11490B	Drip Cover, Black	1
51	H12913	Label, Drip Cover, White	1
52	C11916	Screw, 10-32 X .375 Phillips	3
53	C13100	Nut, M14-2.0 Nylon Insert	1
54	B10734	Strain Relief, Handle	1
55	B11513	Cord, Handle, 14-3 SJTW	1
56	B11762	Terminal Lug, Nylon, Female	2
57	B11465	Switch, DPST, Pushbutton	1
58	B00177	Terminal Lug, Female, QD, .25 X .032	2
59	C00252	Washer, .375 in, Flat	1
60	C11541	Washer, .375 in, Star	1
61	B11518	Switch Insulation	1
62	C00284	Screw, 10-32 X .375 Ground	1
63	B00187	Cable Clamp, Nylon, .43 in.	1
64	B00180-10-3	Ring Terminal, #10 Center	2
65	B11505	Strain Relief Nut, Metal	1
66	C11560	Washer, .93 ID X 1.5 OD	1
67	B11504	Strain Relief, Metal	1
68	H02548-2	Label, Important, Cord	1

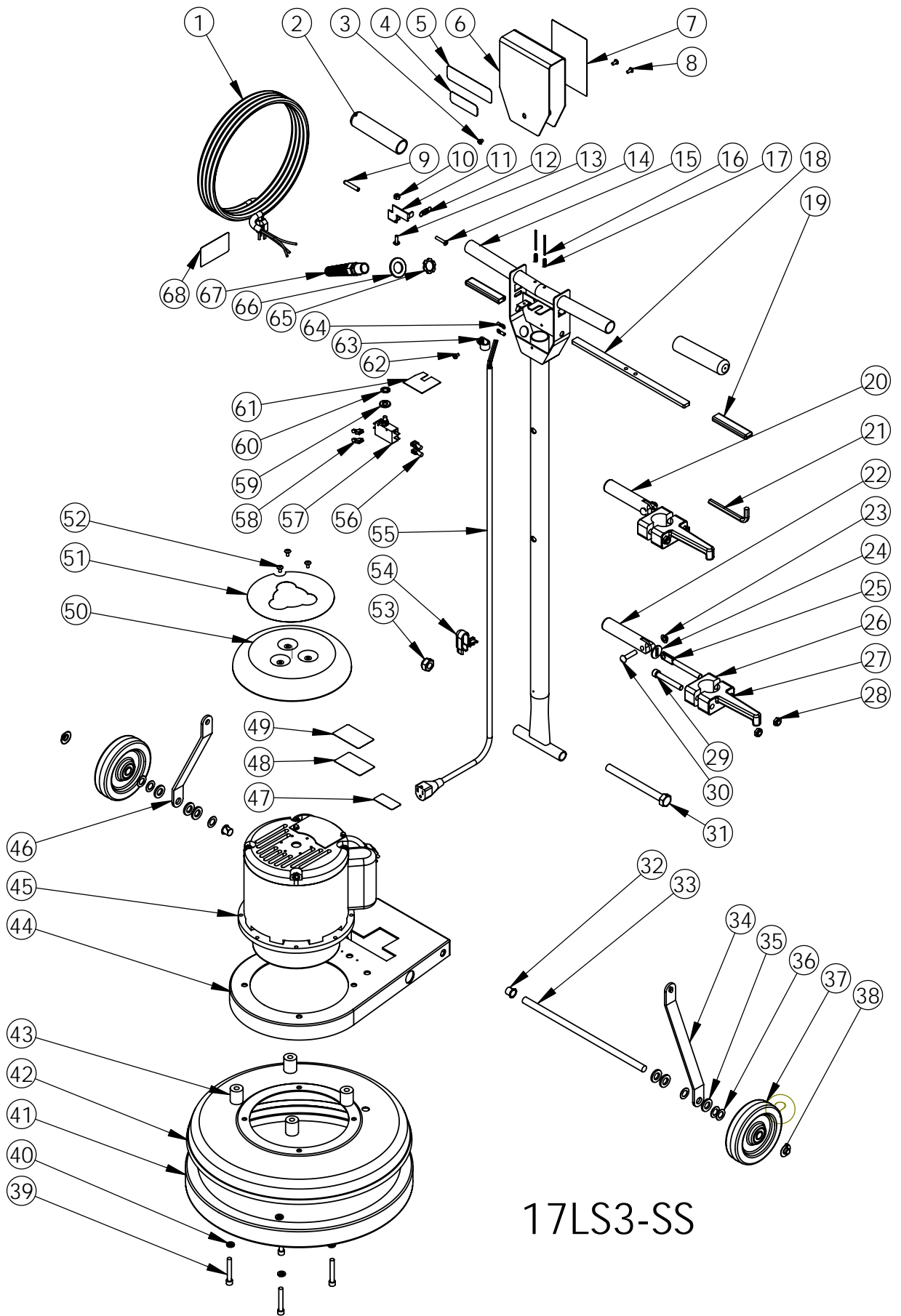

17LS3-SS

# 17LS3-SS

ITEM NO.	PART NUMBER	DESCRIPTION	QTY.
1	B11487	Power Cord, 14-3, 50 FT, SJTW	1
2	K11498	Grip	2
3	C11528	Screw, 10-32 X .25 in	1
4	H12066	Label, 1.5 HP, Saturn	1
5	H11831	Label, EDIC, Black-Silver	1
6	D11496B	Switch Box Cover, Black	1
7	H11493	Label, Safety, Floor Machine	1
8	C11529	Screw, 10-32 X .375 in	2
9	K11519	Lever Grip, Lockout, Black	1
10	C00278	Locknut, 10-32, Nylon, SS	1
11	D11494	Lockout Bracket	1
12	D11524	Spring, Lockout	1
13	C90007	Screw, 10-32 X .625 Phillips, Truss Head, SS	1
14	C11491	Screw, 10-32 X 1 in, SS	1
15	D11479	Handle, Chrome, Floormachine	1
16	C00306	Roll Pin, .125 X 1.75	2
17	D11523	Spring, Trigger	2
18	D11495	Trigger, Zinc Plated	1
19	K11520	Lever Grip, Trigger, Black	2
20	11507A	Assembled Locking Handle, Cord Hook	1
21	C11619	Allen Wrench, .31 in	1
22	D11497	Handle, Locking Clamp	1
23	C11538	Cap Nut, .31 in, Push-On	1
24	C00259	Washer, Slotted, Zinc	1
25	C11536	Spade Bolt, .375-16 X 4 in	1
26	D11507	Cord Hook Clamp	1
27	D11507-2	Cord Hook Body	1
28	C11558	Locknut, Black Oxide, Thin	2
29	C11502	Socket Cap Screw, .375-16 X 2.5 in	1
30	C11537	Dowel Pin, .31 X 1.5 in	1
31	C13101	Screw, Hex Cap, M14-2.0	1
32	K00674	Bushing, .50 in, Nylon	2
33	D11510	Axle, Floor Machine	1
34	D11482	Handle Brace, Right, Black	1
35	C00240	Washer, Shoulder, Nylon	6
36	C11559	Washer, .515 X .875 X .032	6
37	G11943	Wheel, 5 in Saturn	2
38	C02305	Cap Nut, .5in Push-on	2
39	C11501	Socket Cap Screw, .31 - 18	4
40	C00251	Lockwasher, .31, Split	4
41	E11477	Bumper, 17 in Floor Machine	1
42	D11485-SS	Brush Cover, 17 in, Stainless	1
43	K11521	Spacer, Base, Floor Machine	4
44	D11483	Frame, Motor, Black	1
45	G11468	Motor W-Gearbox, 1.5 HP	1
46	D11481	Handle Brace, Left, Black	1
47	H10976-1	Label, UL STD 561-507	1
48	H00565-5	Label, Serial #, Standard	1
49	H03545	Cover, Serial #, Label	1
50	D11490C	Drip Cover, Chrome	1
51	H11830	Label, Saturn, Drip Cover	1
52	C11916	Screw, 10-32 X .375 Phillips	3
53	C13100	Nut, M14-2.0 Nylon Insert	1
54	B10734	Strain Relief, Handle	1
55	B11513	Cord, Handle, 14-3 SJTW	1
56	B11762	Terminal Lug, Nylon, Female	2
57	B11465	Switch, DPST, Pushbutton	1
58	B00177	Terminal Lug, Female, QD, .25 X .032	2
59	C00252	Washer, .375 in, Flat	1
60	C11541	Washer, .375 in, Star	1
61	B11518	Switch Insulation	1
62	C00284	Screw, 10-32 X .375 Ground	1
63	B00187	Cable Clamp, Nylon, .43 in.	1
64	B00180-10-3	Ring Terminal, #10 Center	2
65	B11505	Strain Relief Nut, Metal	1
66	C11560	Washer, .93 ID X 1.5 OD	1
67	B11504	Strain Relief, Metal	1
68	H02548-2	Label, Important, Cord	1

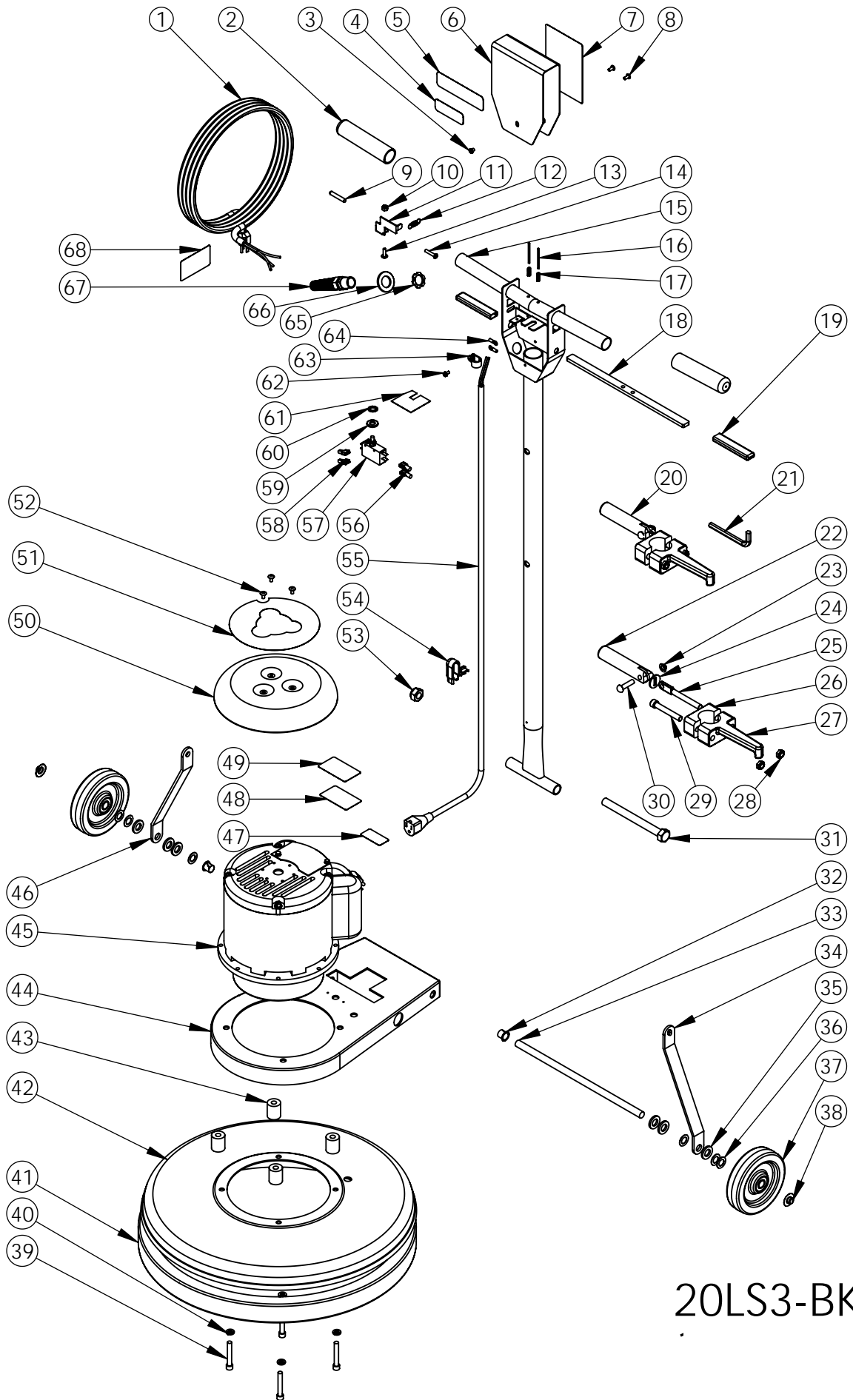

20LS3-BK

# 20LS3-BK

ITEM NO.	PART NUMBER	DESCRIPTION	QTY.
1	B11487	Power Cord, 14-3, 50 FT, SJTW	1
2	K11498	Grip	2
3	C11528	Screw, 10-32 X .25 in	1
4	H12066	Label, 1.5 HP, Saturn	1
5	H11831	Label, EDIC, Black-Silver	1
6	D11496B	Switch Box Cover, Black	1
7	H11493	Label, Safety, Floor Machine	1
8	C11529	Screw, 10-32 X .375 in	2
9	K11519	Lever Grip, Lockout, Black	1
10	C00278	Locknut, 10-32, Nylon, SS	1
11	D11494	Lockout Bracket	1
12	D11524	Spring, Lockout	1
13	C90007	Screw, 10-32 X .625 Phillips, Truss Head, SS	1
14	C11491	Screw, 10-32 X 1 in, SS	1
15	D11479	Handle, Chrome, Floormachine	1
16	C00306	Roll Pin, .125 X 1.75	2
17	D11523	Spring, Trigger	2
18	D11495	Trigger, Zinc Plated	1
19	K11520	Lever Grip, Trigger, Black	2
20	11507A	Assembled Locking Handle, Cord Hook	1
21	C11619	Allen Wrench, .31 in	1
22	D11497	Handle, Locking Clamp	1
23	C11538	Cap Nut, .31 in, Push-On	1
24	C00259	Washer, Slotted, Zinc	1
25	C11536	Spade Bolt, .375-16 X 4 in	1
26	D11507	Cord Hook Clamp	1
27	D11507-2	Cord Hook Body	1
28	C11558	Locknut, Black Oxide, Thin	2
29	C11502	Socket Cap Screw, .375-16 X 2.5 in	1
30	C11537	Dowel Pin, .31 X 1.5 in	1
31	C13101	Screw, Hex Cap, M14-2.0	1
32	K00674	Bushing, .50 in, Nylon	2
33	D11510	Axle, Floor Machine	1
34	D11482	Handle Brace, Right, Black	1
35	C00240	Washer, Shoulder, Nylon	6
36	C11559	Washer, .515 X .875 X .032	6
37	G11943	Wheel, 5 in Saturn	2
38	C02305	Cap Nut, .5in Push-on	2
39	C11501	Socket Cap Screw, .31 - 18	4
40	C00251	Lockwasher, .31, Split	4
41	E11478	Bumper, 20 in Floor Machine	1
42	D11486B	Brush Cover, 20 in, Black	1
43	K11521	Spacer, Base, Floor Machine	4
44	D11483	Frame, Motor, Black	1
45	G11468	Motor W-Gearbox, 1.5 HP	1
46	D11481	Handle Brace, Left, Black	1
47	H10976-1	Label, UL STD 561-507	1
48	H00565-5	Label, Serial #, Standard	1
49	H03545	Cover, Serial #, Label	1
50	D11490B	Drip Cover, Black	1
51	H12913	Label, Drip Cover, White	1
52	C11916	Screw, 10-32 X .375 Phillips	3
53	C13100	Nut, M14-2.0 Nylon Insert	1
54	B10734	Strain Relief, Handle	1
55	B11513	Cord, Handle, 14-3 SJTW	1
56	B11762	Terminal Lug, Nylon, Female	2
57	B11465	Switch, DPST, Pushbutton	1
58	B00177	Terminal Lug, Female, QD, .25 X .032	2
59	C00252	Washer, .375 in, Flat	1
60	C11541	Washer, .375 in, Star	1
61	B11518	Switch Insulation	1
62	C00284	Screw, 10-32 X .375 Ground	1
63	B00187	Cable Clamp, Nylon, .43 in.	1
64	B00180-10-3	Ring Terminal, #10 Center	2
65	B11505	Strain Relief Nut, Metal	1
66	C11560	Washer, .93 ID X 1.5 OD	1
67	B11504	Strain Relief, Metal	1
68	H02548-2	Label, Important, Cord	1

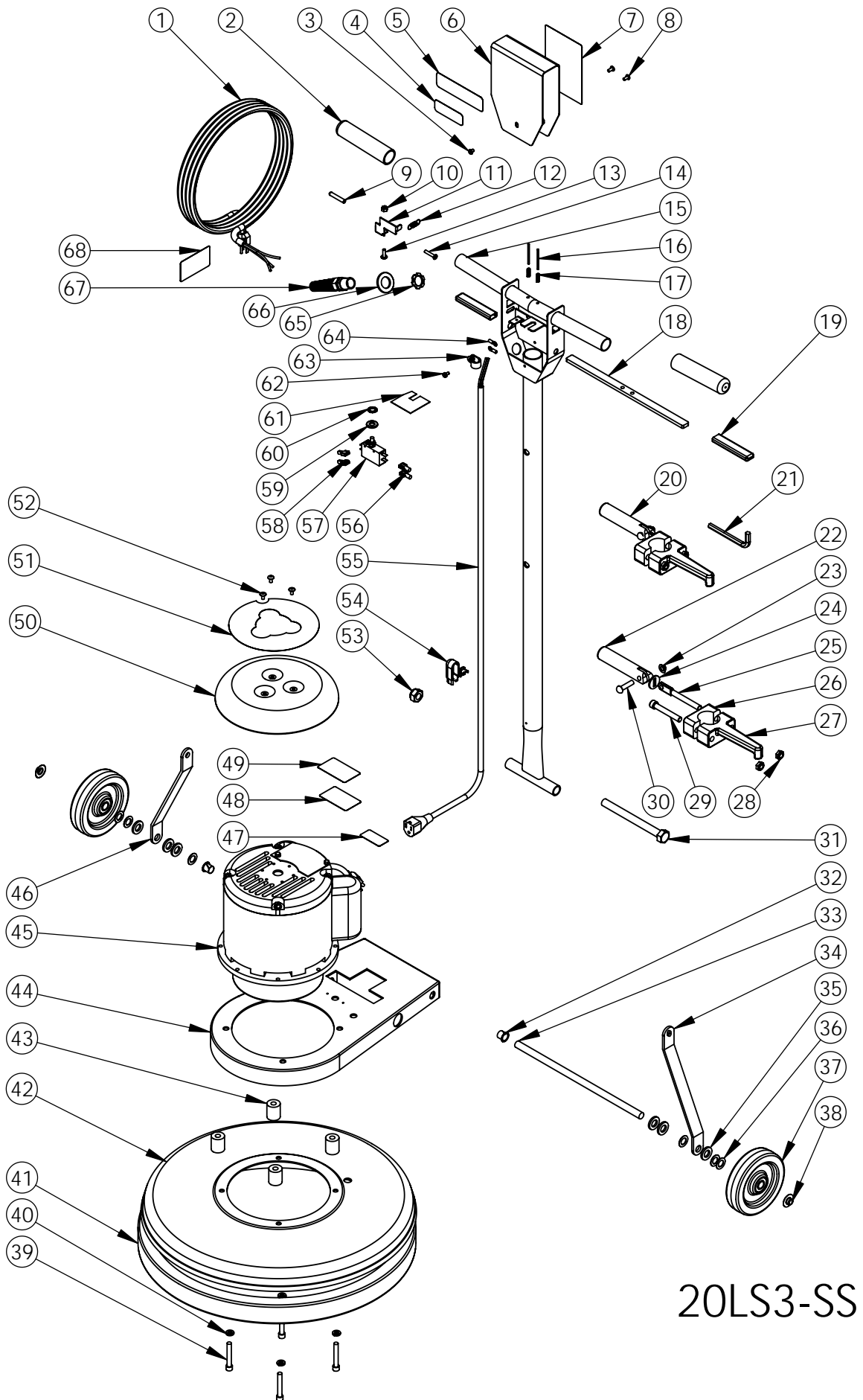

20LS3-SS



# 20LS3-SS

ITEM NO.	PART NUMBER	DESCRIPTION	QTY.
1	B11487	Power Cord, 14-3, 50 FT, SJTW	1
2	K11498	Grip	2
3	C11528	Screw, 10-32 X .25 in	1
4	H12066	Label, 1.5 HP, Saturn	1
5	H11831	Label, EDIC, Black-Silver	1
6	D11496B	Switch Box Cover, Black	1
7	H11493	Label, Safety, Floor Machine	1
8	C11529	Screw, 10-32 X .375 in	2
9	K11519	Lever Grip, Lockout, Black	1
10	C00278	Locknut, 10-32, Nylon, SS	1
11	D11494	Lockout Bracket	1
12	D11524	Spring, Lockout	1
13	C90007	Screw, 10-32 X .625 Phillips, Truss Head, SS	1
14	C11491	Screw, 10-32 X 1 in, SS	1
15	D11479	Handle, Chrome, Floormachine	1
16	C00306	Roll Pin, .125 X 1.75	2
17	D11523	Spring, Trigger	2
18	D11495	Trigger, Zinc Plated	1
19	K11520	Lever Grip, Trigger, Black	2
20	11507A	Assembled Locking Handle, Cord Hook	1
21	C11619	Allen Wrench, .31 in	1
22	D11497	Handle, Locking Clamp	1
23	C11538	Cap Nut, .31 in, Push-On	1
24	C00259	Washer, Slotted, Zinc	1
25	C11536	Spade Bolt, .375-16 X 4 in	1
26	D11507	Cord Hook Clamp	1
27	D11507-2	Cord Hook Body	1
28	C11558	Locknut, Black Oxide, Thin	2
29	C11502	Socket Cap Screw, .375-16 X 2.5 in	1
30	C11537	Dowel Pin, .31 X 1.5 in	1
31	C13101	Screw, Hex Cap, M14-2.0	1
32	K00674	Bushing, .50 in, Nylon	2
33	D11510	Axle, Floor Machine	1
34	D11482	Handle Brace, Right, Black	1
35	C00240	Washer, Shoulder, Nylon	6
36	C11559	Washer, .515 X .875 X .032	6
37	G11943	Wheel, 5 in Saturn	2
38	C02305	Cap Nut, .5in Push-on	2
39	C11501	Socket Cap Screw, .31 - 18	4
40	C00251	Lockwasher, .31, Split	4
41	E11478	Bumper, 20 in Floor Machine	1
42	D11486-SS	Brush Cover, 20 in, Stainless	1
43	K11521	Spacer, Base, Floor Machine	4
44	D11483	Frame, Motor, Black	1
45	G11468	Motor W-Gearbox, 1.5 HP	1
46	D11481	Handle Brace, Left, Black	1
47	H10976-1	Label, UL STD 561-507	1
48	H00565-5	Label, Serial #, Standard	1
49	H03545	Cover, Serial #, Label	1
50	D11490C	Drip Cover, Chrome	1
51	H11830	Label, Saturn, Drip Cover	1
52	C11916	Screw, 10-32 X .375 Phillips	3
53	C13100	Nut, M14-2.0 Nylon Insert	1
54	B10734	Strain Relief, Handle	1
55	B11513	Cord, Handle, 14-3 SJTW	1
56	B11762	Terminal Lug, Nylon, Female	2
57	B11465	Switch, DPST, Pushbutton	1
58	B00177	Terminal Lug, Female, QD, .25 X .032	2
59	C00252	Washer, .375 in, Flat	1
60	C11541	Washer, .375 in, Star	1
61	B11518	Switch Insulation	1
62	C00284	Screw, 10-32 X .375 Ground	1
63	B00187	Cable Clamp, Nylon, .43 in.	1
64	B00180-10-3	Ring Terminal, #10 Center	2
65	B11505	Strain Relief Nut, Metal	1
66	C11560	Washer, .93 ID X 1.5 OD	1
67	B11504	Strain Relief, Metal	1
68	H02548-2	Label, Important, Cord	1

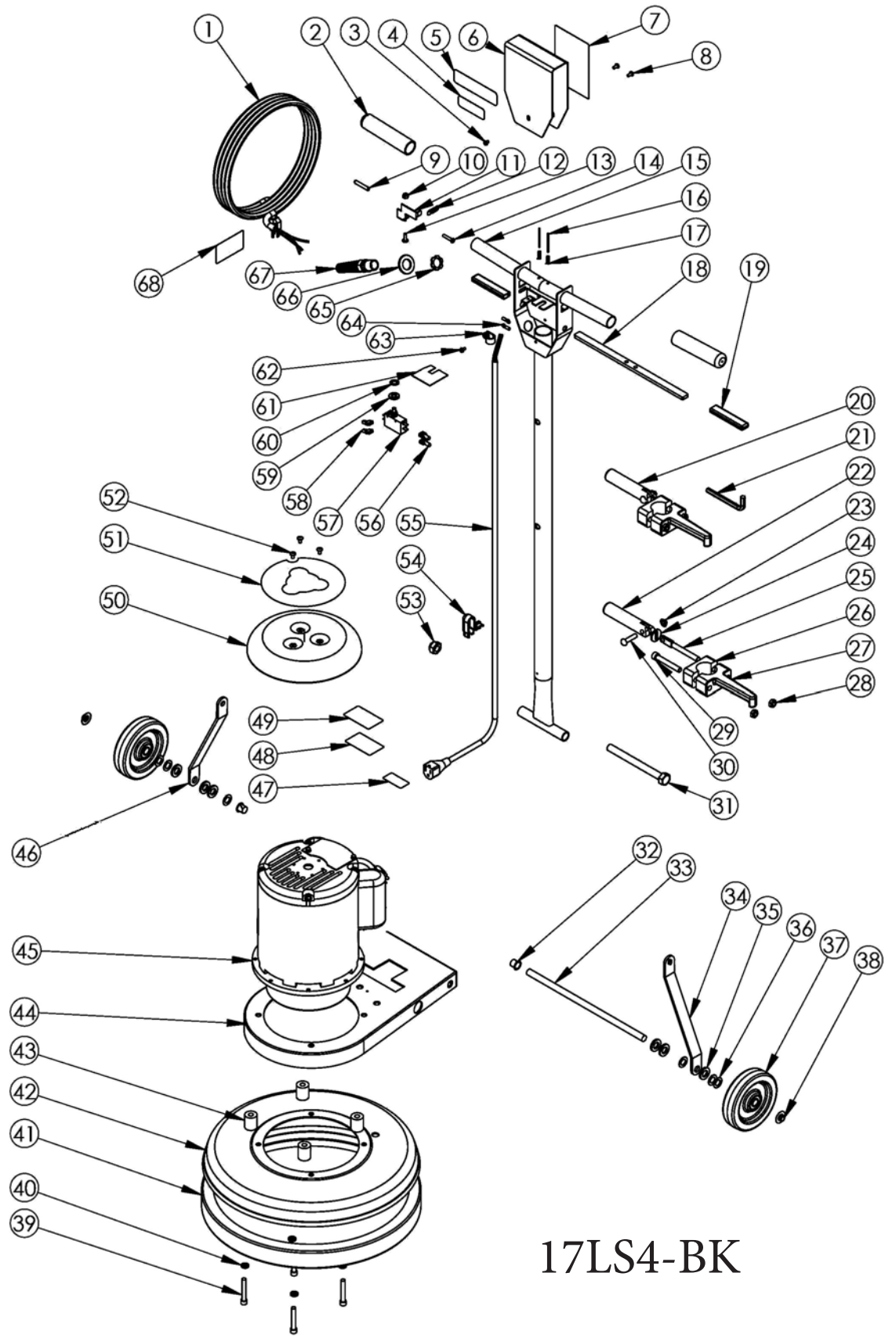

17LS4-BK

# 17LS4-BK

ITEM NO.	PART NUMBER	DESCRIPTION	QTY.
1	B11487	Power Cord, 14-3, 50 FT, SJTW	1
2	K11498	Grip	2
3	C11528	Screw, 10-32 X .25 in	1
4	H12066	Label, 1.5 HP, Saturn	1
5	H11831	Label, EDIC, Black-Silver	1
6	D11496B	Switch Box Cover, Black	1
7	H11493	Label, Safety, Floor Machine	1
8	C11529	Screw, 10-32 X .375 in	2
9	K11519	Lever Grip, Lockout, Black	1
10	C00278	Locknut, 10-32, Nylon, SS	1
11	D11494	Lockout Bracket	1
12	D11524	Spring, Lockout	1
13	C90007	Screw, 10-32 X .625 Phillips, Truss Head, SS	1
14	C11491	Screw, 10-32 X 1 in, SS	1
15	D11479	Handle, Chrome, Floormachine	1
16	C00306	Roll Pin, .125 X 1.75	2
17	D11523	Spring, Trigger	2
18	D11495	Trigger, Zinc Plated	1
19	K11520	Lever Grip, Trigger, Black	2
20	11507A	Assembled Locking Handle, Cord Hook	1
21	C11619	Allen Wrench, .31 in	1
22	D11497	Handle, Locking Clamp	1
23	C11538	Cap Nut, .31 in, Push-On	1
24	C00259	Washer, Slotted, Zinc	1
25	C11536	Spade Bolt, .375-16 X 4 in	1
26	D11507	Cord Hook Clamp	1
27	D11507-2	Cord Hook Body	1
28	C11558	Locknut, Black Oxide, Thin	2
29	C11502	Socket Cap Screw, .375-16 X 2.5 in	1
30	C11537	Dowel Pin, .31 X 1.5 in	1
31	C13101	Screw, Hex Cap, M14-2.0	1
32	K00674	Bushing, .50 in, Nylon	2
33	D11510	Axle, Floor Machine	1
34	D11482	Handle Brace, Right, Black	1
35	C00240	Washer, Shoulder, Nylon	6
36	C11559	Washer, .515 X .875 X .032	6
37	G11943	Wheel, 5 in Saturn	2
38	C02305	Cap Nut, .5in Push-on	2
39	C11501	Socket Cap Screw, .31 - 18	4
40	C00251	Lockwasher, .31, Split	4
41	E11477	Bumper, 17 in Floor Machine	1
42	D11485B	Brush Cover, 17 in, Black	1
43	K11521	Spacer, Base, Floor Machine	4
44	D11483	Frame, Motor, Black	1
45	11476A	HD Motor W-Gearbox, 1.5 HP	1
46	D11481	Handle Brace, Left, Black	1
47	H10976-1	Label, UL STD 561-507	1
48	H00565-5	Label, Serial #, Standard	1
49	H03545	Cover, Serial #, Label	1
50		Drip Cover- provided w motor	1
51	H12913	Label, Drip Cover, White	1
52	C11916	Screw, 10-32 X .375 Phillips	3
53	C13100	Nut, M14-2.0 Nylon Insert	1
54	B10734	Strain Relief, Handle	1
55	B11513	Cord, Handle, 14-3 SJTW	1
56	B11762	Terminal Lug, Nylon, Female	2
57	B11465	Switch, DPST, Pushbutton	1
58	B00177	Terminal Lug, Female, QD, .25 X .032	2
59	C00252	Washer, .375 in, Flat	1
60	C11541	Washer, .375 in, Star	1
61	B11518	Switch Insulation	1
62	C00284	Screw, 10-32 X .375 Ground	1
63	B00187	Cable Clamp, Nylon, .43 in.	1
64	B00180-10-3	Ring Terminal, #10 Center	2
65	B11505	Strain Relief Nut, Metal	1
66	C11560	Washer, .93 ID X 1.5 OD	1
67	B11504	Strain Relief, Metal	1
68	H02548-2	Label, Important, Cord	1

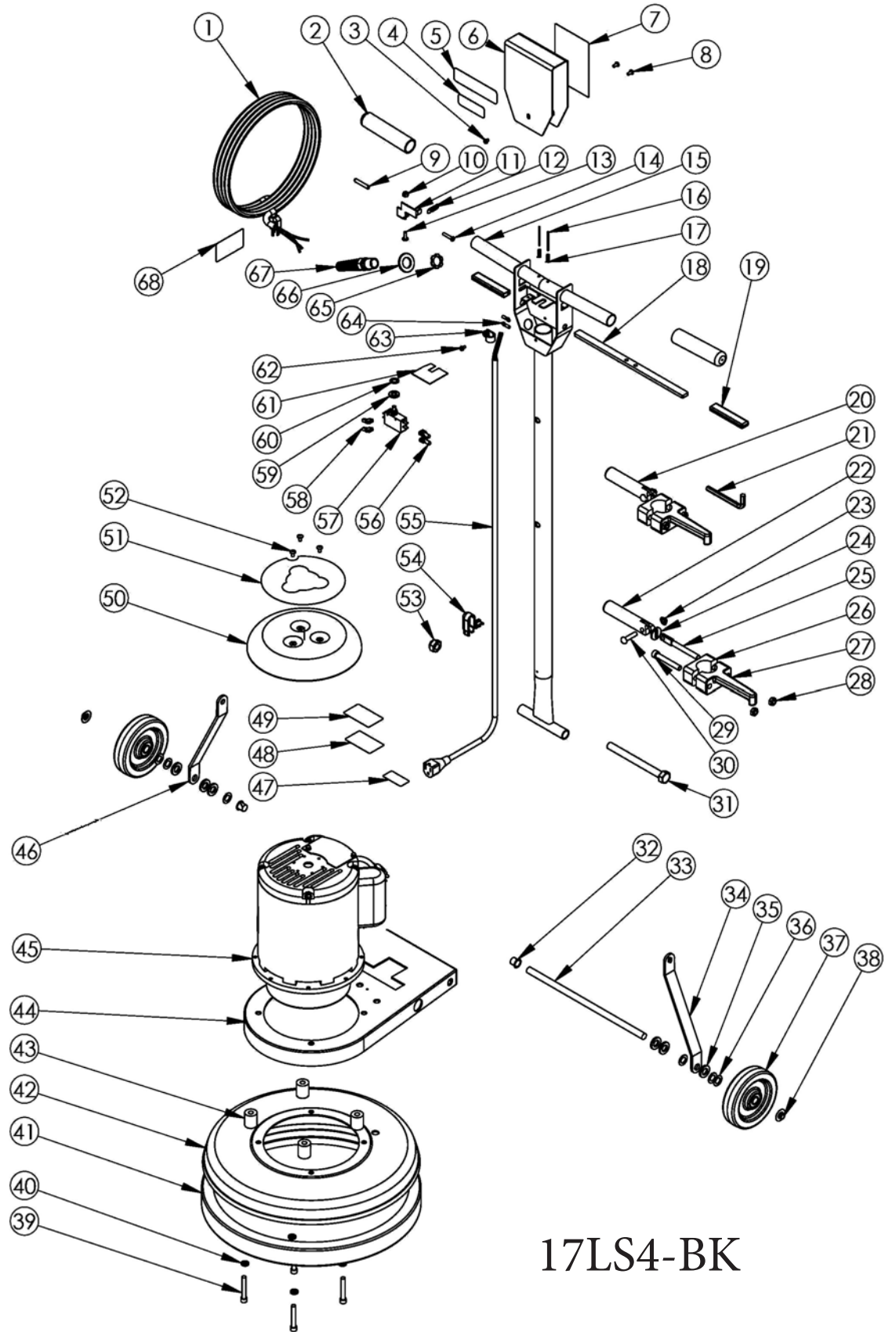

17LS4-BK

# 17LS4-BK

ITEM NO.	PART NUMBER	DESCRIPTION	QTY.
1	B11487 Power Cord, 14-3, 50 FT, SJTW		1
2	K11498 Grip		2
3	C11528 Screw, 10-32 X .25 in		1
4	H12066 Label, 1.5 HP, Saturn		1
5	H11831 Label, EDIC, Black-Silver		1
6	D11496B Switch Box Cover, Black		1
7	H11493 Label, Safety, Floor Machine		1
8	C11529 Screw, 10-32 X .375 in		2
9	K11519 Lever Grip, Lockout, Black		1
10	C00278 Locknut, 10-32, Nylon, SS		1
11	D11494 Lockout Bracket		1
12	D11524 Spring, Lockout		1
13	C90007 Screw, 10-32 X .625 Phillips, Truss Head, SS		1
14	C11491 Screw, 10-32 X 1 in, SS		1
15	D11479 Handle, Chrome, Floormachine		1
16	C00306 Roll Pin, .125 X 1.75		2
17	D11523 Spring, Trigger		2
18	D11495 Trigger, Zinc Plated		1
19	K11520 Lever Grip, Trigger, Black		2
20	11507A Assembled Locking Handle, Cord Hook		1
21	C11619 Allen Wrench, .31 in		1
22	D11497 Handle, Locking Clamp		1
23	C11538 Cap Nut, .31 in, Push-On		1
24	C00259 Washer, Slotted, Zinc		1
25	C11536 Spade Bolt, .375-16 X 4 in		1
26	D11507 Cord Hook Clamp		1
27	D11507-2 Cord Hook Body		1
28	C11558 Locknut, Black Oxide, Thin		2
29	C11502 Socket Cap Screw, .375-16 X 2.5 in		1
30	C11537 Dowel Pin, .31 X 1.5 in		1
31	C13101 Screw, Hex Cap, M14-2.0		1
32	K00674 Bushing, .50 in, Nylon		2
33	D11510 Axle, Floor Machine		1
34	D11482 Handle Brace, Right, Black		1
35	C00240 Washer, Shoulder, Nylon		6
36	C11559 Washer, .515 X .875 X .032		6
37	G11943 Wheel, 5 in Saturn		2
38	C02305 Cap Nut, .5in Push-on		2
39	C11501 Socket Cap Screw, .31 - 18		4
40	C00251 Lockwasher, .31, Split		4
41	E11478 Bumper, 20 in Floor Machine		1
42	D11486B Brush Cover, 20 in, Black		1
43	K11521 Spacer, Base, Floor Machine		4
44	D11483 Frame, Motor, Black		1
45	11476A HD Motor W-Gearbox, 1.5 HP		1
46	D11481 Handle Brace, Left, Black		1
47	H10976-1 Label, UL STD 561-507		1
48	H00565-5 Label, Serial #, Standard		1
49	H03545 Cover, Serial #, Label		1
50	Drip Cover- provided w motor		1
51	H12913 Label, Drip Cover, White		1
52	C11916 Screw, 10-32 X .375 Phillips		3
53	C13100 Nut, M14-2.0 Nylon Insert		1
54	B10734 Strain Relief, Handle		1
55	B11513 Cord, Handle, 14-3 SJTW		1
56	B11762 Terminal Lug, Nylon, Female		2
57	B11465 Switch, DPST, Pushbutton		1
58	B00177 Terminal Lug, Female, QD, .25 X .032		2
59	C00252 Washer, .375 in, Flat		1
60	C11541 Washer, .375 in, Star		1
61	B11518 Switch Insulation		1
62	C00284 Screw, 10-32 X .375 Ground		1
63	B00187 Cable Clamp, Nylon, .43 in.		1
64	B00180-10-3 Ring Terminal, #10 Center		2
65	B11505 Strain Relief Nut, Metal		1
66	C11560 Washer, .93 ID X 1.5 OD		1
67	B11504 Strain Relief, Metal		1
68	H02548-2 Label, Important, Cord		1